

General catalogue IVF



**Certified laboratory equipment and
medical devices**

Quality – Made in Germany

Index

General information about Labotect GmbH

| | |
|---|-------------|
| Company's profile and brief product overview | pp. 05 – 21 |
| The Labotect Quality Assurance System | pp. 05 – 12 |
| Background about Labotect Certificates | pp. 13 – 14 |
| Certificate ISO 13485 | pp. 15 – 16 |
| EC-certificate Directive 93/42/ECC on Medical Devices, Annex II | p. 17 |
| | pp. 19 – 21 |

Products

| | |
|--|---------------|
| Aspirator 3 | pp. 23 – 24 |
| Puncture needles and sets | pp. 25 – 27 |
| Labo C-Top | pp. 29 – 31 |
| Labo C-Top with SAFE Sens® pH monitoring | pp. 33 – 35 |
| Labo Gas Mixer | pp. 37 – 38 |
| Labo Gas Regulator | pp. 39 – 40 |
| CO ₂ Incubator C16 | pp. 41 – 42 |
| CO ₂ Incubator C60 | pp. 43 – 46 |
| CO ₂ Incubator C200 | pp. 47 – 51 |
| CO ₂ Incubator C201 | pp. 53 – 57 |
| SAFE Sens® pH monitoring system | pp. 59 – 60 |
| Gasmonitor | pp. 61 – 62 |
| LaboDat+ | pp. 63 – 64 |
| Disinfectant - Fermacidal D2® | pp. 65 – 66 |
| Disinfectant - Manoform® | pp. 67 – 68 |
| Disinfectant – Icepur® | pp. 69 – 70 |
| Incubator-Filter-Box | p. 71 |
| Gas In-Line Filter | p. 73 |
| InControl 1050 | pp. 75 – 76 |
| Hot Plate 062 | p. 77 |
| Hot Plate 100 | p. 79 |
| Hot Plate A3 | p. 81 |
| Hot Plate A4 | p. 83 |
| Blockthermostat | p. 85 |
| CellTrans+ | pp. 87 – 88 |
| CellTrans 2018 | p. 91 |
| Thermo Cell Transporter 3018 | p. 93 |
| Aluminum heating blocks | pp. 95 – 96 |
| Embryo Transfer Catheter Set | pp. 97 – 98 |
| Insemination Catheter | p. 99 |
| Holding Pipettes | pp. 101 – 102 |
| Microinjection Pipettes | pp. 103 – 104 |
| Active Vibration Isolation | pp. 105 – 108 |

**Dem Fortschritt
verpflichtet**

**der Natur
verbunden**

www.labotect.com

Innovation, Erfahrung und Kompetenz seit über 45 Jahren

Qualität – Made in Germany

Labotect Labor-Technik-Göttingen GmbH – gelegen im Herzen Deutschlands – entwickelt, produziert und vertreibt eine große Auswahl an Produkten für den Einsatz im Bereich assistierte Reproduktion, in der Medizin und in naturwissenschaftlichen Laboren. Herausragende Qualität und enger Kundenkontakt bestimmen die Firmenphilosophie seit über 45 Jahren. Das Ziel ist es, höchsten Ansprüchen mit innovativen Entwicklungen gerecht zu werden.

Auch wendet sich Labotect dem Thema Nachhaltigkeit zu. Die Firma hat bei ihren hochwertigen Geräten schon immer auf äußerste Langlebigkeit Wert gelegt. Erhalt und Reparatur durch erfahrenes Servicepersonal hat Priorität. Bei zukünftigen Entwicklungen wird ein geringer Energieverbrauch einen noch höheren Stellenwert bekommen. Außerdem wird bei Materialfragen intensiv auf Recyclebarkeit und Umweltverträglichkeit geachtet.

Labotect wurde 1971 als Handelsfirma für Laborgeräte gegründet. Wenige Jahre später wurde eine eigene F&E Abteilung mit dem Schwerpunkt der assistierten Reproduktionstechniken (ART) gegründet. So wurde Labotect zu einem der Pioniere auf diesem Gebiet. Heute wird die Firma weltweit in mehr als 40 Ländern durch ein starkes Netzwerk an zuverlässigen und geschulten Repräsentanten vertreten. Als Hersteller von Medizinprodukten ist Labotect gemäß ISO 13485 für Entwicklung, Produktion, Vertrieb und Service für Geräte und Instrumente für die assistierte Reproduktion, Gynäkologie, Chirurgie und Gewebekultur zertifiziert.

Optimale Kulturbedingungen für Ihre Zellen!

Inkubationstechnik ist einer der Schwerpunkte von Labotect. Ein Vorteil der CO₂-Inkubatoren ist die perfekte Kontaminationskontrolle durch modernste Technik und Bauweise. Die Inkubatoren vereinen einen hohen Sicherheitsstandard mit einem komfortablen Design. Äußerst kurze Erholzeiten für alle regulierbaren Parameter sind grundlegende Eigenschaften aller Labotect-CO₂-Inkubatoren.

Zusätzlich zur Inkubationstechnik beinhaltet die breite Produktpalette Geräte und Verbrauchsmaterialien für die assistierte Reproduktion, Laborequipment und sterile Einwegprodukte für gynäkologische und laparoskopische Eingriffe.

Labotect bietet einen **Embryo Transfer Katheter** in drei Längen - 150 mm, 190 mm und 230 mm:

1. Das sterile Katheter-Set besteht aus einem vorgebogenen Führungsrohr und einem Innenkatheter mit einem metallverstärkten Schaft.
2. Beide Teile haben eine eingearbeitete cm-Markierung, um die Penetrationstiefe zu kontrollieren.
3. Über einen Stellring können die Penetrationstiefe und die Richtung am Führungsrohr eingestellt werden.
4. Durch den Kugelabschluss des Führungsrohrs ist der Katheter auch bei schwierigen anatomischen Verhältnissen atraumatisch einsetzbar.



Für das Absaugen von Oocyten und Follikeln bieten wir **Punktionsnadeln** und eine **Aspirationspumpe**:

- **Nadeln und Nadelsets für die Follikel-Punktion:**

1. Facettenschliff
2. Ergonomisches Griffstück
3. Echofeld geschliffen oder geätzt
4. Medizinprodukt Klasse IIa
5. Individuelle Sets auf Nachfrage

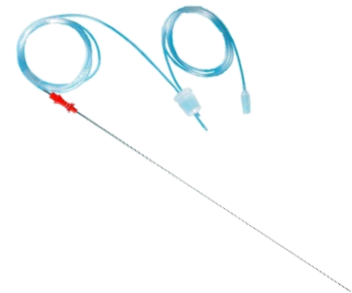

- **Aspirator 3:**

1. Einfache Bedienung durch elektrisches Fußpedal
2. Lange Lebensdauer, sehr zuverlässig und sehr leise
3. Präzise Unterdruckregelung
4. Überlaufschutz
5. Zugelassenes Medizinprodukt



Darüber hinaus umfasst unsere Produktpalette CO₂-Inkubatoren in den Größen 16, 60 und 200 Litern.

Vorteile unserer Inkubatoren **C60** und **C200**:

1. Aktive Sterilbefeuchtung

Um das Kontaminationsrisiko zu minimieren besitzen diese Inkubatoren eine aktive Sterilbefeuchtung mit einem Verdampfermodul, welches mit 120 °C und einem externen Wasserreservoir arbeitet (kein Wasser im Inneren des Inkubators vorhanden). Destilliertes Wasser gelangt über eine Pumpe in den Verdampfer, wird dort auf 120 °C erhitzt und in sehr feinen Tropfen verdampft. Dieser sterile Wasserdampf versorgt den Inkubator mit Feuchtigkeit, welche über einen Sensor reguliert wird. Durch die aktive Befeuchtung werden die Erholzeiten deutlich reduziert.

2. Zweistrahl-Infrarot-Sensor

Dieser Sensor stellt präzise Messwerte und sehr kurze Erholzeiten des CO₂-Wertes sicher, da externe Effekte (Temperatur, Feuchtigkeit) eliminiert sind.

3. Direktheizung

Das intelligente Temperatur-Kontrollsystem und die voneinander unabhängigen, ganzflächig temperierten Innenwände und die temperierte Tür sorgen für trockene Wände ohne Kältebrücken und eine homogene Temperaturverteilung im Inneren.

4. Zugelassenes Medizinprodukt

5. Optional: LaboDat+ Software

Mit dieser Software können alle Daten der Inkubatoren über eine bestimmte Zeitspanne gemessen und gespeichert werden.



Vorteile unseres neuesten Inkubators C201:

1. 7" Farbtouchdisplay
2. UV-Dekontamination (Option)
3. Partikelfilter (P3) im Luftstrom
4. Graphische Darstellung der Messwerte über 2 h oder 24 h (T, CO₂, rH, O₂)
5. Zugangskontrolle über Zahlencode auf dem Touchdisplay mit mechanischer Notentriegelung (Option)
6. Kabeldurchführung (Accessport)
7. RS485- oder Ethernet-Schnittstelle



Vorteile unseres Inkubators C16:

1. Sehr kompakte und platzsparende Bauweise
2. Direktheizung von Innenwänden und Tür
3. Zweistrahl-Infrarot-Sensor
4. Zugelassenes Medizinprodukt



Vorteile unseres Tischinkubators Labo C-Top:

1. Zwei identische Kammern mit unabhängiger, individueller Benutzung (Feuchtigkeit, Mischgas, Temperatur)
2. Optimale Temperaturübertragung und optimaler Durchfluss des Gases
3. Direktheizung von Deckel und Boden
4. Optimale Begasung mit Mischgas
5. Zuverlässiges Befeuchtungssystem
6. Praktisches Glas-Bedienpanel
7. Sehr kurze Aufheiz- und Erholzeiten



Wir bieten das **SAFE Sens® pH-Wert-Überwachungssystem** für unsere Großinkubatoren **C60, C200 und C201**, sowie das in unseren Tischinkubator **Labo C-Top** integrierte SAFE Sens® System:

1. Kontinuierliche, nicht-invasive, unabhängige Messung des pH-Wertes
2. Echtzeitdaten des pH-Wertes jede Minute oder alle 30 Minuten für bis zu 7 Tage
3. Exakte Messergebnisse: $\pm 0,05$ in einem pH-Bereich von 7,00 bis 7,60
4. Monitoring von bis zu 8 Kammern oder Inkubatoren mit einer TrakStation™
5. TrakPods in den Labo C-Top integriert; ohne Belegung eines wertvollen Kulturplatzes



Vorteile von unserem Gasmixer:

1. Stellt vorgemischtes Gas (CO_2 , N_2 und O_2) für bis zu 3 Tischinkubatoren zur Verfügung
2. Individuelle Einstellung der CO_2 und O_2 -Konzentration
3. Anschluss von CO_2 und N_2 -Gasflaschen nötig, O_2 wird aus der Umgebungsluft gewonnen
4. Bypass für die Versorgung anderer externer Geräte mit Mischgas:
 - Inkubationskammern von Mikroskopen
 - Externe Überwachung der Parameter durch Labotect InControl



Vorteile von unserem InControl:

1. Temperatur-Messung; Bereich: 0 – 100 °C
2. CO_2 -Messung; Bereich: 0 – 10 %
3. O_2 -Messung mit optionalem Sensor; Bereich: 0 – 100 %
4. Messwerterfassung in Echtzeit



5. Messung und Dokumentation mehrerer Inkubatoren
6. Daten-Download via USB
7. PC-Software DataVISUAL`09 inklusiv
8. Ausgerüstet mit wieder aufladbaren Li-Ion-Batterien und Netzteil
9. Keine separate Ladestation

Das folgende Laborequipment vervollständigt die weite Produktpalette von Labotect:

Transport-Inkubatoren:

Wir bieten unseren **Thermo-Cell-Transporter 3018** für den sicheren und vielseitigen Gebrauch und unseren **CellTrans 2018** für die sichere und mobile Aufbewahrung von Zellmaterial, Proben, Nährböden usw. an



Zudem bieten einen weiteren Transportinkubator an, den **CellTrans+**, der die Möglichkeit bietet, die Inkubatorluft zu befeuchten sowie Temperatur und CO₂-Gehalt zu kontrollieren. Dieser eignet sich zudem als Back-Up für Ihre Zellen im Falle eines Strom- oder Inkubatorausfalls.



Hot Plates 100, A3, 062 und A4:

für das Labor und die Wissenschaft



Blockthermostat:

für eine gleichmäßige Temperaturverteilung



IVF Workstation:

Mit integriertem aktiven Schwingungs-Isolationssystem für Schwingungs-Dämpfung selbst im niedrigen Frequenzbereich.



...und vieles mehr: www.labotect.com !

The Labotect Quality Assurance System

Quality Assurance or QA is seen by Labotect as an integral part of our Quality Management System. Every employee and staff member is made aware of the delicate environment our products are used in and need to accept these high standards set forth in our quality policy.

Approach

When developing our products we seek out the feedback and cooperation of renowned specialists in their respective field of work. Raw materials are chosen carefully to suit the purpose they are going to be used for. Mostly, this means they have to pass a test about biocompatibility, among others. Also, suppliers are chosen according to their proficiency at what they do. Each supplier must agree that he can be audited by us, our Notified Body and foreign authorities who might request this. The great majority of our suppliers come from Germany.

It is our believe that quality must be produced. It cannot be tested into a product later on.

Various Tests

Before a batch of disposables is released it needs to pass a Mouse Embryo Assay and a LAL-Endotoxin test. Pass criteria are > 80 % blastocysts hatching in the Mouse Embryo Assay and an endotoxin value of < 20 EU/ml. You will find these criteria to be one of the strictest in the industry. The tests are performed by an independent and accredited laboratory (Embryotech Inc.). Certificates from the independent laboratory are available on request.

Our CO₂ incubators play a vital role in different cell culture applications. To ensure their performance every unit has to pass a cell growth-test before it is released for sale.

Standards

Everything evolving around the design, development, manufacture and sale of our product conforms to at least the ISO 13485 standard with its already exacting demands. Additionally, we do fulfil requirements of many countries around the world, where our products are registered, e.g. Egypt, China, India, USA, Brazil, Croatia, Israel, to name but a few.

Reviews

Our quality management system is audited once a year and every three years we have to undergo re-certification. That means that at least two auditors turn our quality management system up-side down for 2-3 days. Furthermore, we now face the possibility of un-announced audits by our Notified Body once every three or five years.

Additionally, our Notified Body (TÜV SÜD Product Service GmbH) has long since implemented a policy to re-view the technical documentation for the products. It is compulsory for Notified Bodies since 2010 to prepare and implement an algorithm after which all products of a manufacturer in Class IIa and above are reviewed once a year.

Labotect has three product groups in Class IIa: our incubators, the Aspirator and our ovarian biopsy sets and needles. So, within the validity of our ISO-certificate (three years) each product group is reviewed fully and within the validity of our EC certificate (five years) the relevant product groups are reviewed one and a half times.

Upholding these high standards takes a lot of time and effort but we feel that you and your customers deserve nothing less.



Background about Labotect Certificates

In 1998, Labotect implemented a Quality Management System according to ISO 9002. In 2003, as one of the first medical device manufacturers in Germany, Labotect was certified according to DIN EN ISO 13485:2003.

ISO 13485

Contrary to the ISO 9001, the ISO 13485 certificate refers to many other rules, regulations and laws to be fulfilled (i.e. ISO/TR14969 Guidance on the application of ISO 13485, ISO 14971 Application of Risk Management for Medical devices). Its key features are the following:

- Defined product specifications
- Defined production process including suppliers
- Risk Analyses
- Biological and Clinical data for design validation
- Product identification and traceability
- Traceability of components

Directive 93/42/EEC

Furthermore, Labotect is certified according to the Medical Device Directive (MDD) or Directive 93/42/EEC, which is the most important regulatory instrument for the detection of safety and medical-technical performance of medical devices in the European Economic Area. The key features of Council Directive 93/42 EEC are as follows:

- Essential requirements (13 named in the Directive, including sub clauses they are 84: safety, functionality, design, materials etc.)
- Conformity to harmonized standards
- Classification
- Conformity assessment procedures
- Registration of responsible persons
- Unannounced audits by the Notified Body with min. 2 Auditors for one day (at least once in a three year period)

CE-label

All our products have a CE-label, which claims, that this device conforms to the correspondent EC regulation and all essential requirements are met. The CE-label is mandatory for all medical devices and allows the access to the complete EC market.

Moreover, the label stands for:

- Equivalent market clearance in all member states
- Improved patient and customer protection
- Decentralized market control
- Explicit responsibility of the manufacturer
- National law enforcement

Scope of ISO certificates

As many users do not have in focus, the scope of the ISO certificate is defined by the manufacturer before the certification process, and therefore makes a big difference.

The scope of Labotects ISO-certificate:

“Design and development, production, sale and service of sterile medical devices (intrauterine catheters, biopsy needles and sets for ultrasonic aspiration, micropipettes) and medical devices for assisted reproduction and for cell and tissue cultures; Installation, maintenance and repair of laboratory equipment and active medical products in addition to logistics services”

You may compare this to the scope of competitor’s ISO-certificates.



Certificate

No. Q5 070354 0010 Rev. 00

Holder of Certificate: **Labotect Labor-Technik-Göttingen GmbH**



Kampweg 12
37124 Rosdorf
GERMANY

Facility(ies):

BeLoTec GmbH
Kampweg 12, 37124 Rosdorf, GERMANY

Labotect Labor-Technik-Göttingen GmbH
Kampweg 12, 37124 Rosdorf, GERMANY

Certification Mark:



Scope of Certificate:

Design and development, production, sale and service of sterile medical devices (intrauterine catheters, biopsy needles and sets for ultrasonic aspiration, micropipettes) and medical devices for assisted reproduction and for cell and tissue cultures; Installation, maintenance and repair of laboratory equipment and active medical devices in addition to logistics services

Applied Standard(s):

EN ISO 13485:2016
Medical devices - Quality management systems - Requirements for regulatory purposes (ISO 13485:2016)
DIN EN ISO 13485:2016

The Certification Body of TÜV SÜD Product Service GmbH certifies that the company mentioned above has established and is maintaining a quality management system, which meets the requirements of the listed standard(s). See also notes overleaf.

Report No.: 713149250

Valid from: 2019-04-12

Valid until: 2022-04-11

Date, 2019-04-12

Stefan Preiß



Product Service

EC Certificate

Full Quality Assurance System

Directive 93/42/EEC on Medical Devices (MDD), Annex II excluding (4)
(Devices in Class IIa, IIb or III)

No. G1 18 04 70354 009

Manufacturer: Labotect Labor-Technik-Göttingen GmbH

Kampweg 12
37124 Rosdorf
GERMANY



Facility(ies):

Labotect Labor-Technik-Göttingen GmbH
Kampweg 12, 37124 Rosdorf, GERMANY

BeLoTec GmbH
Kampweg 12, 37124 Rosdorf, GERMANY

Product

Category(ies):

Sterile medical products and medical products for assisted reproduction, consisting of biopsy needles and sets for follicle aspiration, suction pumps, cell and tissue culture systems

The Certification Body of TÜV SÜD Product Service GmbH declares that the aforementioned manufacturer has implemented a quality assurance system for design, manufacture and final inspection of the respective devices / device categories in accordance with MDD Annex II. This quality assurance system conforms to the requirements of this Directive and is subject to periodical surveillance. For marketing of class III devices an additional Annex II (4) certificate is mandatory. See also notes overleaf.

Report No.: 713132064

Valid from: 2018-07-11

Valid until: 2023-07-10

Date, 2018-07-11

Stefan Preis

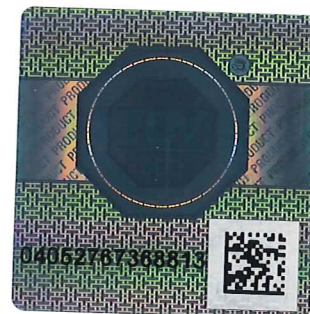

TÜV SÜD Product Service GmbH is Notified Body with identification no. 0123

Page 1 of 1



Product Service

EC Certificate

Production Quality Assurance System

Directive 93/42/EEC on Medical Devices (MDD), Annex V

(Devices in class I in sterile conditions, sterilised systems or procedure packs)

No. G2S 17 05 70354 008

Manufacturer: Labotect Labor-Technik-Göttingen GmbHKampweg 12
37124 Rosdorf
GERMANY**Facility(ies):** Labotect Labor-Technik-Göttingen GmbH
Kampweg 12, 37124 Rosdorf, GERMANY**Product Category(ies):** Sterile medical devices for assisted reproduction techniques

The Certification Body of TÜV SÜD Product Service GmbH declares that the aforementioned manufacturer has implemented a quality assurance system for manufacture in accordance with MDD Annex V. This quality assurance system covers those aspects of manufacture concerned with securing and maintaining sterile conditions of the respective devices / device categories and conforms to the requirements of this Directive. It is subject to periodical surveillance. See also notes overleaf.

Report No.: 713108748**Valid from:** 2017-08-28**Valid until:** 2022-08-27**Date,** 2017-07-07

Stefan Preiß

TÜV SÜD Product Service GmbH is Notified Body with identification no. 0123

Page 1 of 1

Aspirator 3

Quality – Made in Germany



Precise aspiration pump for follicular puncture

Advantages of Aspirator 3:

- Approved medical device
- Easy handling by electrical pedal
- Long durability
- High reliability
- Very silent
- Constant control of negative pressure
- Safe by overflow protection

Basic equipment:

- Aspirator 3
- Foot pedal
- Mains adapter
- 2 x overflow bottle, 2 x blocking filter and tubing

REF 14193 (without hotplate)

REF 13907 (with integrated hotplate)

Picture shows device with integrated hotplate (optional), heating block and puncture set from Labotect

Optional accessory:

- Integrated hotplate

REF 13907 (Aspirator 3 with hotplate)

- Movable support stand

REF 14287



Technical data:

- According to Directive 93/42/EEC: Class IIa
- EN 10079 conform: high vacuum, low flow
- Negative pressure:
 - 0 – 500 mmHg \pm 0 – 666 mbar
- Volume of overflow vessel: 100 ml
- Dimensions:
 - ~ 408 x 130 x 250 (w x h x d in mm)
- Weight: ~ 7.6 kg
- Connection for aspiration tubing: \varnothing 2 to 4 mm
- Power supply: 230 V AC, 50/60 Hz or 115 V AC, 50/60 Hz, 85 VA
- Safety class: I
- Device type: BF
- Hotplate (optional):
 - Temperature range: 30 °C – 45 °C
 - Heating up time: < 10 min.
- Connection for potential compensation

Puncture needles and -sets

Quality – Made in Germany

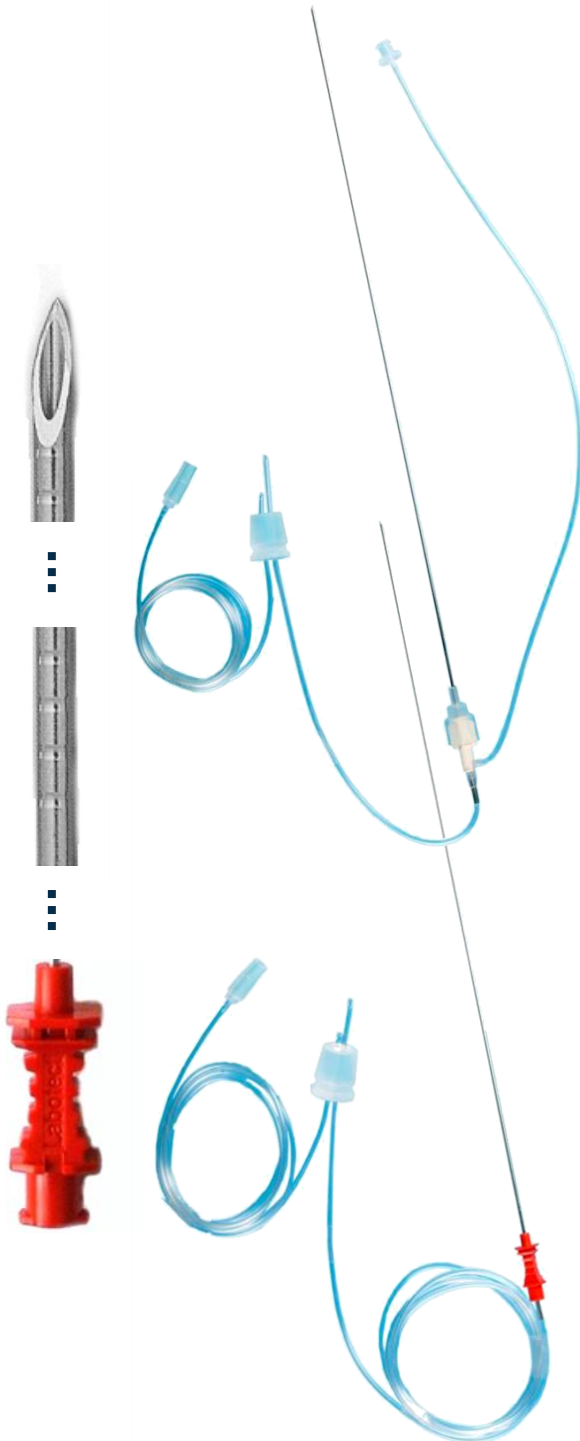

Labotect ovarian biopsy needles and sets are developed for medical use in the field of assisted reproduction

Product features:

- Needles and sets for follicular puncture
- Facet bevel
- Ergonomic handle
- Grinded or corroded echo marking
- Validated ETO-sterilization
- MEA/LAL tested
- Medical device class IIa

Single lumen puncture sets

with **corroded echo marking, without flushing tube:**

| REF | Needle length (mm) | Outer diameter of the needle (mm / G) | Plug for tubes with ... ml | Length of tubing from needle to plug (mm) | Length of tubing from plug to aspirator (mm) | Luer connection on plug |
|-------|--------------------|---------------------------------------|----------------------------|---|--|-------------------------|
| 13441 | 300 | 1.4 / 17 | 14 | 1300 | 1000 | yes |
| 13444 | 300 | 1.4 / 17 | 26 | 1300 | 1000 | no |
| 15138 | 330 | 1.0 / 19 | 14 | 1300 | 1000 | yes |
| 16783 | 300 | 1.4 / 17 | 14 | 800 | 800 | yes |
| 16785 | 330 | 1.0 / 19 | 14 | 800 | 800 | yes |

with **corroded echo marking and flushing tube:**

| REF | Needle length (mm) | Outer diameter of the needle (mm / G) | Plug for tubes with ... ml | Length of tubing from needle to plug (mm) | Length of tubing from plug to aspirator (mm) | Luer connection on flushing tube |
|-------|--------------------|---------------------------------------|----------------------------|---|--|----------------------------------|
| 13443 | 300 | 1.4 / 17 | 14 | 1300 | 1000 | yes |

Length of tubing for flushing: 1000

| | | | | | | |
|-------|-----|----------|----|-----|----|-----|
| 16445 | 300 | 1.4 / 17 | 14 | 750 | 30 | yes |
|-------|-----|----------|----|-----|----|-----|

Length of tubing for flushing: 750

with **grinded echo marking, without flushing tube:**

| REF | Needle length (mm) | Outer diameter of the needle (mm / G) | Plug for tubes with ... ml | Length of tubing from needle to plug (mm) | Length of tubing from plug to aspirator (mm) | Luer connection on plug |
|---------|--------------------|---------------------------------------|----------------------------|---|--|-------------------------|
| 13438 | 300 | 1.4 / 17 | 14 | 1300 | 1000 | yes |
| 13440 | 300 | 1.4 / 17 | 26 | 1300 | 1000 | no |
| 13450 | 300 | 1.4 / 17 | 14 | 500 | 1800 | no |
| 13451* | 300 | 1.4 / 17 | 14 | 1300 | 1000 | no |
| 13452* | 300 | 1.4 / 17 | 14 | 500 | 1000 | no |
| 13452L* | 300 | 1.4 / 17 | 14 | 1000 | 1000 | no |

*with firm tubing

Double lumen puncture sets

with grinded echo marking and flushing tube:

| REF | Needle length (mm) | Outer diameter of the needle (mm / G) | Plug for tubes with ... ml | Length of tubing from needle to plug (mm) | Length of tubing from plug to aspirator (mm) | Luer connection on flushing tube |
|-------|--------------------|---------------------------------------|----------------------------|---|--|----------------------------------|
| 13463 | 330 | 1.6 / 16 | 14 | 390 | 1000 | yes |

Length of tubing for flushing: 350 mm

| | | | | | | |
|-------|-----|----------|----|-----|-----|-----|
| 16784 | 330 | 1.6 / 16 | 14 | 800 | 800 | yes |
|-------|-----|----------|----|-----|-----|-----|

Length of tubing for flushing: 800 mm



Grinded echo marking



Corroded echo marking

Labo C-Top

Quality – Made in Germany



Table top incubator for up to date, individual cell cultivation

Advantages of Labo C-Top:

- Approved medical device
- Two independent and separate incubation chambers
- Parameters (gas flow, temperature) can be adjusted individually
- Optimized gassing with premixed gas
- Optimized temperature distribution by double heated chamber from top and bottom
- Reliable humidity system
- Current value of relative humidity is displayed (% rH)
- Very fast heating up and recovery times
- Convenient glass control panel
- Space saving

Technical data:

Exterior:

- Dimensions 403 x 225 x 155 mm (w x d x h)
- Weight 8.8 kg

Interior:

- Two chambers with 0.5 liters each
- Mixed load possible

Temperature:

- Overall heating from top and bottom of each chamber
- Range 30 °C – 42 °C from 7 °C above ambient temperature
- Stability / uniformity $\pm 0.1 / 0.3$ °C

Gassing:

- Premixed gas
- Gas flow adjustable between 20 ml/min and 30 ml/min
- Flow rate after opening the lid (automatic gas purge): 250 ml/min for 3 minutes

Connection values:

- 110 – 230 V AC, 50/60 Hz, 100 VA
- Primary pressure for gas 0.8 bar
- Ambient temperature 18 °C – 30 °C

Classification:

- Safety class I
- Class IIa for every usage according to EC Directive 93/42/EEC
- Device is compliant to EN 61010

REF 14876



Additional equipment:

- Labo Gas Mixer provides mixed gas (CO₂, N₂ and atmospheric oxygen)

REF 15583

Product features:

Incubation chambers:

- Aluminum milled and eloxated
- In the lower part:
 - Slots provide full contact to culture dishes
 - Adaption for humidity block
 - Gas inlet
- Easy cleaning
- Independent, for use with (per chamber):
 - 4 x IVF 4-well dishes 66 x 66 mm
 - 4 x Petri dishes Ø 60 mm
 - 10 x Petri dishes Ø 35 mm

Temperature:

- Overall heating from top and bottom
- Very homogeneous temperature distribution

Humidity:

- Humidification by means of humidity block
- Reservoir sufficient for 4 days (when gassing with 20 ml/min)
- Humidity block autoclavable
- Humidity alarm disengageable
- Current value of relative humidity is displayed (% rH)

Gassing:

- Connection of premixed gas (CO₂, O₂ < 21 %, N₂)
- Separate measuring and regulation of gas flow for each chamber
- Automatic gas purge when closing the chamber

Recovery times:

- Short recovery times for all adjustable parameters through microprocessor controlled regulation

Use of glass panel:

- Homogeneous glass cover
- Sensoric buttons integrated in glass
- Image of placements for marking inserted dishes at the glass cover
- Easy operation and menu navigation
- Lit LCD at working place height

Trouble check system:

- Optical and acoustic alarm in case of set point deviation and defective sensor
- Independent over-temperature protection
- Remote alarm

Options:

- PC software LaboDat+ for documentation of incubator's parameters
- Second gas inlet for use of different gas mixtures for each chamber
- Lockable lids

Interfaces:

- Remote alarm (potential free)
- RS485 interface for data logging with optional available PC software LaboDat+

For Labo C-Top we offer the following options:



Labo C-Top with lockable lids:

- Higher security for your cultures
- Limited access to the cultures

REF 15070



Labo C-Top with second gas inlet:

- Every chamber to be gassed with different mixtures at the same time!

REF 15069

Labo C-Top with SAFE Sens® pH monitoring



Benchtop incubator with integrated SAFE Sens® technology for continuous, non-invasive pH monitoring

Advantages of Labo C-Top with SAFE Sens® pH monitoring:

- All advantages and options of Labo C-Top combined with state-of-the-art pH monitoring system
- Independent monitoring of the pH-value in Labo C-Top chambers
- TrakPods™ integrated in surface of Labo C-Top without use of valuable dish space
- Real time monitoring of the pH-value every minute or every 30 minutes for up to 7 days
- Accurate measurements: ± 0.05 in a range of pH 7.00 to 7.60
- SAFE Sens® measurement technology utilizes a patented and proven LED-based optical fluorescent system
- Included Software for data recording capabilities and automatic alerts (by e-mail)
- Monitoring of up to 8 chambers with one TrakStation™

REF 16377

Product features of Labo C-Top with SAFE Sens® pH monitoring:

- Changes in pH immediately visible due to continuous monitoring
- Monitoring without staff intervention and lid opening
- No petri-dish required (non-invasive)
- No costly, time consuming calibration required:
 - One qc² alignment tool needed per laboratory
 - Automatically adjusts fluorescent signal to restore to factory settings
 - No outside calibration services required, no incubator down time

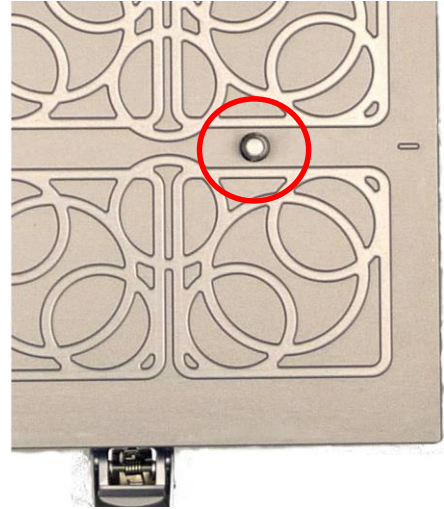

Open Labo C-Top with SAFE Sens® sv²-sensor (red marking)



Options for Labo C-Top with SAFE Sens® pH monitoring system

- Integrated SAFE Sens® TrakPod™ either on both sides or side of choice
- With or without SAFE Sens® TrakStation™
- Labo C-Top with lockable lids
- Labo C-Top with second gas inlet

Technical data of Labo C-Top:

Exterior:

- Dimensions 403 x 225 x 155 mm (w x d x h)
- Weight 8.8 kgs

Interior:

- Two chambers with 0.5 liters each
- Mixed load possible

Temperature:

- Overall heating from top and bottom of each chamber
- Range 30 °C – 42 °C from 7 °C above ambient temperature
- Stability / uniformity ± 0.1 °C / 0.3 °C

Gassing:

- Premixed gas
- Gas flow adjustable between 20 ml/min and 30 ml/min
- Flow rate after opening the lid (automatic gas purge):
250 ml/min for 3 minutes

Connection values:

- 110 – 230 V AC, 50/60 Hz, 100 VA
- Primary pressure for gas 0.8 bar
- Ambient temperature 18 °C – 30 °C

Classification:

- Safety class I
- Class IIa for every usage according to EC Directive 93/42/EEC
- Device is compliant to EN 61010

Incubation technique

Product features of Labo C-Top:

Incubation chambers:

- Aluminum milled and eloxated
- In the lower part:
 - Slots provide full contact to culture dishes
 - Adaption for humidity block
 - Gas inlet
- Easy cleaning
- Independent, for use with (per chamber):
 - 4x IVF 4-well dishes 66x66 mm
 - 4x Petri dishes Ø 60 mm
 - 10x Petri dishes Ø 35 mm

Temperature:

- Overall heating from top and bottom
- Very homogeneous temperature distribution

Humidity:

- Humidification by means of humidity block
- Reservoir sufficient for 4 days (when gassing with 20 ml/min)
- Humidity block autoclavable
- Humidity alarm disengageable
- Current value of relative humidity is displayed (% rH)

Gassing:

- Connection of premixed gas (CO₂, O₂ < 21 %, N₂)
- Separate measuring and regulation of gas flow for each chamber
- Automatic gas purge when closing the chamber

Recovery times:

- Short recovery times for all adjustable parameters through microprocessor controlled regulation

Use of glass panel:

- Homogeneous glass cover
- Sensoric buttons integrated in glass
- Image of placements for marking inserted dishes at the glass cover
- Easy operation and menu navigation
- Lit LCD at working place height

Trouble check system:

- Optical and acoustic alarm in case of set point deviation and defective sensor
- Independent over-temperature protection
- Remote alarm

Options:

- PC software LaboDat+ for documentation of incubator's parameters
- Second gas inlet for use of different gas mixtures for each chamber
- Lockable lids

Interfaces:

- Remote alarm (potential free)
- RS485 interface for data logging with optional available PC software LaboDat+



SAFE Sens® qc² alignment tool on TrakPod™'s sv² sensor in Labo C-Top

Additional equipment:

- Labo Gas Mixer provides mixed gas (CO₂, N₂ and atmospheric oxygen)

REF 15583

Accessories:

SAFE Sens® sterile sv²-sensor (10 pieces)

REF 16370

SAFE Sens® qc² alignment tool

REF 16371

The SAFE Sens® pH-monitoring technology is also available for large format incubators.

Labo Gas Mixer

Quality – Made in Germany



Features:

- Provides mixed gas (CO₂, N₂ and atmospheric oxygen) for incubators
- Individual setting of CO₂ and O₂ concentration
- Connection for CO₂ & N₂ gas bottles, O₂ will be retrieved from ambient air
- Integrated In-Line-Filters (exchangeable)
- Mixed gas supply for up to three Labo C-Tops
- Bypass for other external devices:
 - Mixed gas supply of incubation chambers used with microscopes
 - External control of CO₂ concentration by use of Labotect InControl
- Anytime adjustable concentration of required mixture of gases
- Convenient glass control panel

REF 15583

Technical data:

- Dimensions: 21.0 x 27.5 x 15.5 cm (w x d x h) incl. filter
- CO₂ control:
 - Range 0 – 10 % / stability ± 0.3 % CO₂
 - Dual beam IR sensor
- O₂ control < 21 %:
 - Range 5 – 21 % / stability ± 0.3 % O₂
 - Nernst cell
- Removable gas quantity max. 1000 ml/min
- Pressure range gas port: 0.8 – 1.5 bar
- Gas flow bypass: 50 – 300 ml/min
- RS485 interface for connection to *LaboDat+*
- Remote alarm
- Power supply: 110 – 240 V AC, 50/60 Hz, 45 W
- Safety class I

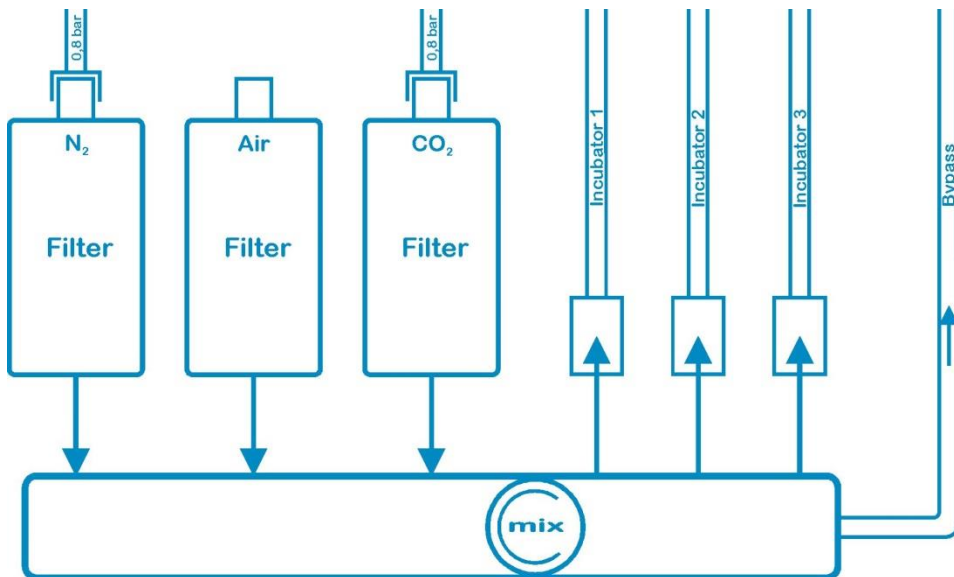

Rev. 6_02/2020

Labo Gas Regulator

Quality – Made in Germany



For two different adjustable gas outlet pressures out of one gas supply

Technical data:

- Outer dimensions:
191 x 88 x 208 mm (w x d x h)
- Weight: 2.2 kg
- Gas inlet pressure: max. 3.0 bar
- Gas outlet pressure: 0 – 2.5 bar
- Use with CO₂, N₂
- Wall mounting possible (opening at the back)

REF 15971

Characteristics:

- Necessary for the fluctuation-free operation of the Labo Gas Mixer (continuous gas consumption) if the same gas source is used to provide gas for CO₂ incubators (pulsed gas consumption)
- Adapted for gas supply by gas bottle with gas pressure reducer or facility installed gas supply
- Suitable for operation in various environments where different gas pressures need to be generated from one supply source

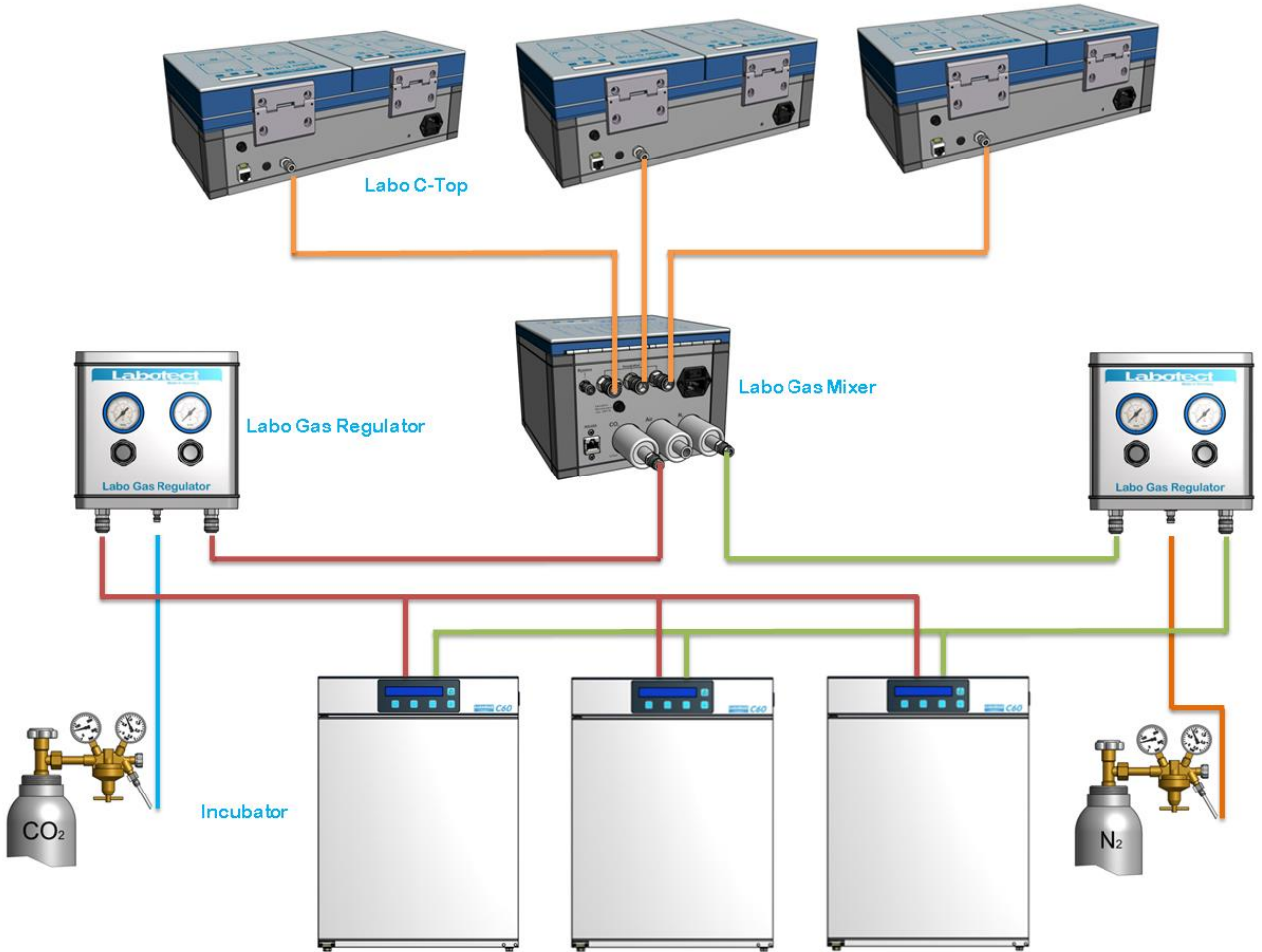

Picture: Application example of Labo Gas Regulator with Labo Gas Mixer, 3 x Labo C-Top and 3 x C60 incubators

CO₂ Incubator C16

Quality – Made in Germany

Your first choice for excellent cell cultivation



REF 14209 (without O₂ control)

REF 14452 (with O₂ control)

Small incubator with an inner volume of 16 liters

Advantages of C16:

- Approved medical device
- CO₂ sensor:
 - Dual beam infrared sensor
 - Very precise measurement
 - Very short recovery times
 - Long-term stable
- Direct heating:
 - Independent over-all heating of inner walls and door
 - Homogeneous temperature distribution in the interior
 - Very short recovery times
- Very compact and space saving construction
- Optional:
 - O₂ control
 - PC software LaboDat+

Product features:

Interior:

- Electro-polished stainless steel with coved corners
- Shelves and ductwork easily removable for cleaning purposes

Temperature:

- Panel heated interior chamber and door

Humidity supply:

- Via an internal water reservoir

CO₂:

- Dual beam infrared sensor
- Measurements independent from temperature and humidity

Very short recovery times:

- For all adjustable parameters through optimized microprocessor control

Easy handling:

- Menu-driven
- Backlit LCD display
- Membrane keypad

Diagnostic system:

- Optical and acoustical alarm if set point deviation or sensor defect occurs
- Door monitoring
- Air monitoring
- Hardware self-test
- Remote alarm

Options:

- O₂ control: connection for N₂

Interfaces:

- Remote alarm (potential free)
- RS485-interface for data-logging with optional PC software LaboDat+

Technical data:

Exterior:

- Dimensions 290 x 330 x 480 mm (w x d x h)

Interior:

- Volume 16 l
- Electro-polished stainless steel
- 2 shelves 205 x 230 mm (w x d)

Temperature:

- Panel heated interior chamber and door
- Range 27 °C – 42 °C starting 5 °C above ambient temperature
- Stability / uniformity: ± 0.1 °C / 0.3 °C

CO₂ control:

- Dual beam infrared sensor
- Range 0 – 10 % CO₂
- Stability 0.1 % CO₂

O₂ control < 21 % (optional):

- Measurement with galvanic sensor
- Connection of N₂
- Range 1 – 21 % O₂

Connection values:

- 110 – 230 V AC, 50/60 Hz, 60 W
- Inlet pressure for gas 0.8 bar
- Ambient temperature 18 °C – 30 °C

Classification:

- Safety class I
- Class IIa for every usage according to EC Directive 93/42/EEC
- Device is compliant to EN 61010

CO₂ Incubator C60

Quality – Made in Germany

Your first choice for excellent cell cultivation



Incubator with 60 liter chamber capacity

REF 14093

Advantages of C60:

- Approved medical device
- Active sterile humidity:
 - External water reservoir
 - Distilled water is vaporized at 120 °C
 - Minimized risk of contamination
 - Humidity sensor (rH)
 - Very fast recovery
- CO₂-sensor:
 - Dual beam infrared sensor
 - Very precise measurement
 - Very fast recovery
 - Long-term stable
- Heating:
 - Independent six-sided direct heating
 - Homogeneous temperature distribution in incubation chamber
 - Very fast recovery
- Optional:
 - O₂-control
 - Subdivided inner glass door with 4 small doors
 - Lockable front door
 - Access port
 - PC software LaboDat+

Product features:

Interior chamber:

- Electro-polished stainless steel with rounded corners
- No tools required for quick assembly and disassembly of interior components

Temperature:

- Panel heated chamber and door
- Intelligent temperature control system avoids condensation in inner chamber

Active sterile Humidity supply:

- External water supply container

CO₂-control:

- Dual beam infrared sensor
- Measurement independent from temperature and humidity

Fast recovery:

- For all adjustable parameters through optimized microprocessor control

Easy handling:

- Menu guided
- Large, backlit LCD
- Foil keyboard

Diagnostic system:

- Visual and acoustic alarm if set point deviation or sensor defect occurs
- Door monitoring
- Remote alarm

Options:

- O₂-control: connection of N₂
- Subdivided inner glass door with 4 small doors
- Lockable front door
- Access port \varnothing 30 mm

Interfaces:

- Alarm contact (potential free)
- RS485 interface for connection of optional available PC software LaboDat+

Technical data:

Exterior chamber:

- Dimensions 510 x 540 x 720 mm (w x d x h)

Interior chamber:

- Chamber volume 60 l
- Electro-polished stainless steel
- Shelves height adjustable

Temperature:

- Panel heated interior chamber and door
- Adjustable range 27-42 °C starting 5 °C above ambient temperature
- Stability / uniformity: ± 0.1 °C / ± 0.3 °C
- Over-temperature alarm: 32-47 °C

CO₂-control:

- Dual beam infrared sensor
- Adjustable range 0-10 % CO₂
- Stability ± 0.1 % CO₂

O₂-control < 21 % (optional):

- Measurement with galvanic sensor
- Connection of N₂
- Adjustable range 1-21 % O₂

Humidity:

- Active sterile humidity generated by vaporization module at 120 °C
- Measuring range 0-98 % rH, adjustable range 60-95 % rH

Supply:

- 230 V AC, 50/60 Hz or 115 V AC, 50/60 Hz, 160 W
- Inlet pressure 0.8 bar
- Ambient temperature 18-30 °C

Classification:

- Safety class I
- Class IIa for all usage according to EC-Directive 93/42/EEC
- Conform to EN 61010

Accessories & options:



Subdivided inner glass door – for even faster recovery

- 4 small inner doors
- Even faster recovery of all parameters
- Even lower gas consumption
- Easy cleaning of inner doors



Access port

- Ø 30 mm
- Located in the upper right corner of the incubation chamber
- Sealing plug in scope of supply



Lockable front door - higher security for your cultures



Stacking kit – for safe positioning

- Safe, easy and space-saving positioning of the devices in the laboratory

REF 10789 High frame stand, 105 cm height, white coated steel

Our C60 incubators are available with O₂-control (O₂ < 21 %)

Recommended Accessories for active sterile humidity supply:



AEROpart® HUM

- sterile and pyrogen-free water
1000 ml

REF 16150



Magnetic hook

- diameter 48 mm

REF 15595



Intrafix® Air (B. Braun)

- I.V. administration set
tubing length 150 cm

REF 15417

CO₂ Incubator C200

Quality – Made in Germany

Your first choice for excellent cell cultivation



Incubator with 200 liter chamber capacity

REF 13946

Advantages of C200:

- Approved medical device
- Active sterile humidity:
 - External water reservoir
 - Distilled water is vaporized at 120 °C
 - Minimized risk of contamination
 - Humidity sensor (rH)
 - Very fast recovery
- CO₂-sensor:
 - Dual beam infrared sensor
 - Very precise measurement
 - Very fast recovery
 - Long-term stable
- Direct heating:
 - Independent six-sided direct heating
 - Homogeneous temperature distribution in incubation chamber
 - Very fast recovery
- Optional:
 - O₂-control
 - Subdivided inner glass door with 6 small doors
 - Lockable front door
 - Access port
 - PC software LaboDat+

Product features:

Interior chamber:

- Electro-polished stainless steel with rounded corners
- No tools required for quick disassembly and assembly of interior components

Temperature:

- Panel heated chamber and door
- Intelligent temperature control system avoids condensation in inner chamber

Active sterile Humidity supply:

- External water supply container

CO₂-control:

- Dual beam infrared sensor
- Measurement independent from temperature and humidity

Fast recovery :

- For all adjustable parameters through optimized microprocessor control

Easy handling:

- Menu guided
- Large, backlit LCD
- Foil keyboard

Diagnostic system:

- Visual and acoustic alarm if set point deviation or sensor defect occurs
- Door monitoring
- Remote alarm

Options:

- O₂-control: connection of N₂
- Subdivided inner glass door with 6 small doors
- Lockable front door
- Access port Ø 30 mm

Interfaces:

- Alarm contact (potential free)
- RS485 interface for connection of optional available PC software LaboDat+

Technical data:

Exterior chamber:

- Dimensions 680 x 690 x 930 mm (w x d x h)

Interior chamber:

- Chamber volume 200 l
- Electro-polished stainless steel
- Shelves height adjustable

Temperature:

- Panel heated interior chamber and door
- Adjustable range 27-42 °C starting 5 °C above ambient temperature
- Stability / uniformity: ±0.1 °C / ±0.3 °C
- Over-temperature alarm: 32-47 °C

CO₂-control:

- Dual beam infrared sensor
- Adjustable range 0-10 % CO₂
- Stability ±0.1 % CO₂

O₂-control < 21 % (optional):

- Measurement with galvanic sensor
- Connection of N₂
- Adjustable range 1-21 % O₂

Humidity:

- Active sterile humidity generated by vaporization module at 120 °C
- Measuring range 0-98 % rH, adjustable range 60-95 % rH

Supply:

- 230 V AC, 50/60 Hz or 115 V AC, 50/60 Hz, 200 W
- Inlet pressure 0.8 bar
- Ambient temperature 18-30 °C

Classification:

- Safety class I
- Class IIa for all usage according to EC-Directive 93/42/EEC
- Conform to EN 61010

Accessories & options:



Subdivided inner glass door - for even faster recovery

- 6 small inner doors
- Even faster recovery of all parameters
- Even lower gas consumption
- Easy cleaning of inner doors
- Scope of supply
 - 6 split shelves 500 x 222 mm (d x w) each
 - 3 shelves 502 x 481 mm (d x w) each



Access port

- Ø 30 mm
- Located in the upper left corner inside the incubation chamber
- Sealing plug in scope of supply



Lockable front door - higher security for your cultures



Stacking kit – for safe positioning

- Safe, easy and space-saving positioning of the devices in the laboratory

- REF 10649 Underframe, 15 cm height, white coated steel
- REF 10681 High frame stand, 115 cm height, white coated steel



Roller base

- For mobile positioning of the devices in the laboratory, on lockable wheels, preventing roller base movement

- REF 14411 Roller base, 15 cm height, on lockable wheels

Our C200 incubators are available with O₂-control (O₂ < 21 %)

Recovery rates following 30 s door opening:

- Subdivided inner door
- Standard inner door

Temperature

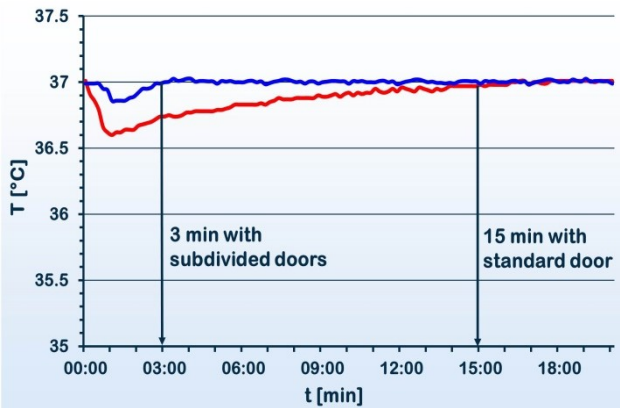

CO₂

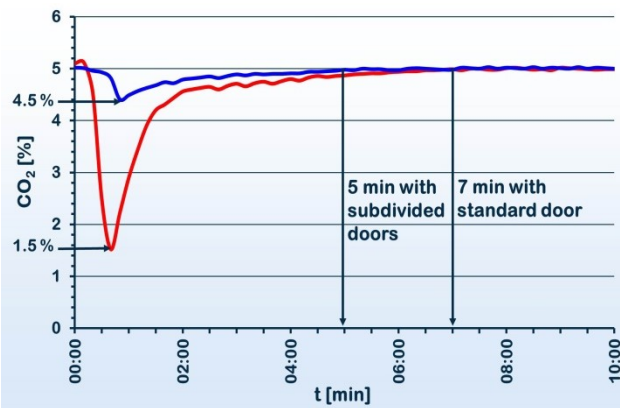

Relative Humidity

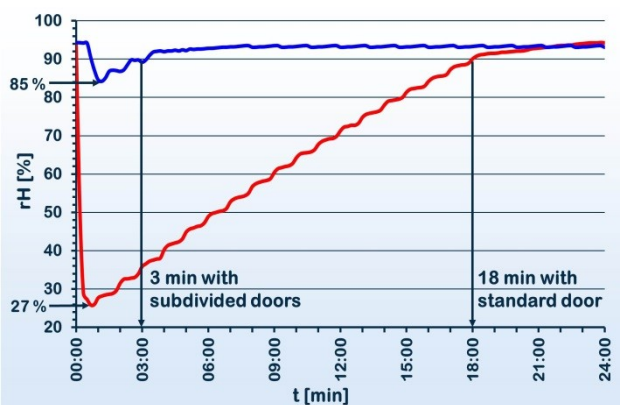

Recommended Accessories for active sterile humidity supply:



AEROpart® HUM

- sterile and pyrogen-free water
1000 ml

REF 16150



Magnetic hook

- diameter 48 mm

REF 15595



Intrafix® Air (B. Braun)

- I.V. administration set
tubing length 150 cm

REF 15417

CO₂ Incubator Labo C201

Quality – Made in Germany

Your first choice for
excellent cell cultivation
with optional
UV decontamination



Incubator with 200 liter
chamber capacity

REF 15245

Advantages of Labo C201:

- 7" colour touch screen
- UV decontamination (optional)
- Particle filter (P3) within airflow
- Graphical display of recorded parameters of the past 2 h or 24 h (T, CO₂, rH, and O₂)
- Access control via number code (optional)
- RS485 or ethernet interface
- Active sterile humidity supply:
 - External water reservoir
 - Distilled water is vaporized at 120 °C
 - Minimized risk of contamination
 - Humidity sensor
 - Very fast recovery
- CO₂-sensor:
 - Dual beam infrared sensor
 - Very precise measurement
 - Very fast recovery
 - Long-term stable
- Direct heating:
 - Independent six-sided direct heating
 - Homogeneous temperature distribution in incubation chamber
 - Very fast recovery
- Further options:
 - O₂-control
 - Subdivided inner glass door with 6 small doors
 - PC software LaboDat+

Product features:

Interior:

- Electro-polished stainless steel with rounded corners
- Shelves and ductwork easily removable for cleaning
- Access port \varnothing 30 mm

Temperature:

- Intelligent temperature control system avoids condensation in inner chamber

Humidity supply:

- Active sterile humidity via external water supply container

CO₂-control:

- Dual beam infrared sensor
- Measurement independent from temperature and humidity

Fast recovery:

- For all adjustable parameters

Easy handling:

- Menu guided 7" colour touch display
- Graphical display of recorded parameters of the past 2 h or 24 h

Diagnostic system:

- Visual and acoustic alarm if set point deviation or sensor defect occurs
- Door monitoring
- Remote alarm

Options:

- O₂-control: connection of N₂
- Subdivided inner glass door with 6 small doors
- UV decontamination routine
- Access control via numerical code
- PC software LaboDat+

Interfaces:

- Alarm contact (potential free)
- RS485 or Ethernet interface

Technical data:

Exterior:

- Dimensions 720 x 700 x 870 mm (w x d x h)

Interior:

- Chamber volume 200 l
- Electro-polished stainless steel
- Shelves height adjustable

Temperature:

- Panel heated interior chamber and door
- Range 27-42 °C starting 5 °C above ambient temperature
- Stability / uniformity: ± 0.1 °C / ± 0.3 °C
- Over-temperature alarm: 32-47 °C

CO₂-control:

- Dual beam infrared sensor
- Adjustable range 0-10 % CO₂
- Stability ± 0.1 % CO₂

O₂-control < 21 % (optional):

- Measurement with galvanic sensor
- Connection of N₂
- Adjustable range 1-21 % O₂

Humidity:

- Active sterile humidity generated by vaporization module at 120 °C
- Measuring range 0-98 % rH, adjustment range 60-95 % rH

Access port:

- \varnothing 30 mm

Supply:

- 230 V AC, 50/60 Hz or 115 V AC, 50/60 Hz, 250 VA
- Inlet pressure 0.8 bar
- Ambient temperature 18-30 °C

Classification:

- Safety class I
- Conform to EN 61010

Accessories & options:

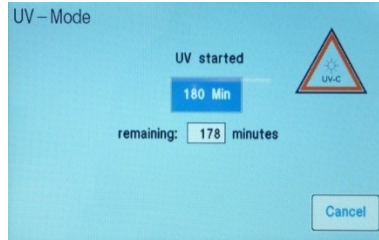

UV decontamination

- Individual start by user
- Duration: 180 minutes
- Short-wave UV radiation (UV-C radiation, < 280 nm)
- UV mode is terminated immediately when the door is opened

Subdivided inner glass door - for even faster recovery

- 6 small inner doors
- Even faster recovery of all parameters
- Even lower gas consumption
- Easy cleaning of inner doors
- Scope of supply
 - 6 split shelves 474 x 222 mm (d x w) each
 - 3 shelves each 485 x 454 mm (d x w) each



Each Labotect CO₂ incubator passes an individual cell-growth test prior to delivery!

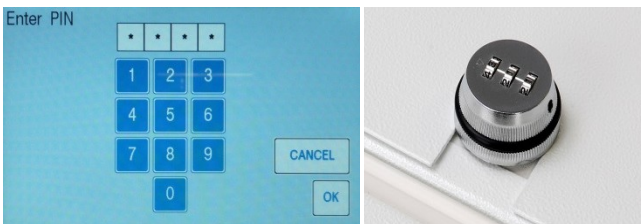

Access control - higher security for your cultures

- Access control via touch screen
- Mechanical unlocking in case of power failure (emergency release)

Our Labo C201 incubators are available with O₂-control (O₂ < 21 %)



Accessories & options:



Stacking kit - for safe positioning

- Safe, easy and space-saving positioning of the devices in the laboratory

REF 10649 Floor stand, 15 cm height, white coated steel

REF 10681 High frame stand, 115 cm height, white coated steel



Roller base

- For mobile positioning of the devices in the laboratory, on lockable wheels, preventing roller base movement

REF 14411 Roller base, 15 cm height, on lockable wheels

Recovery rates following 30 s door opening:

- Subdivided inner door
- Standard inner door

Temperature

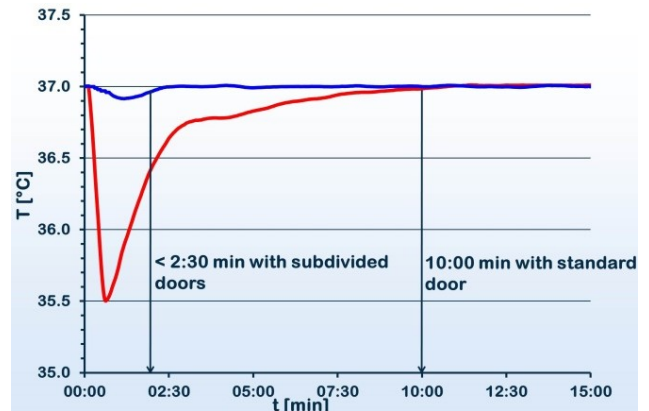

CO₂

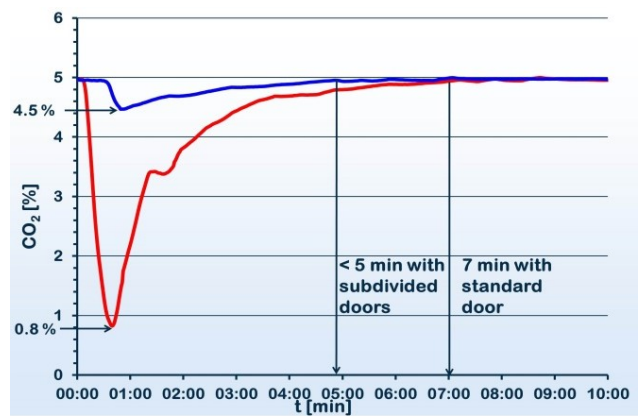

Relative Humidity

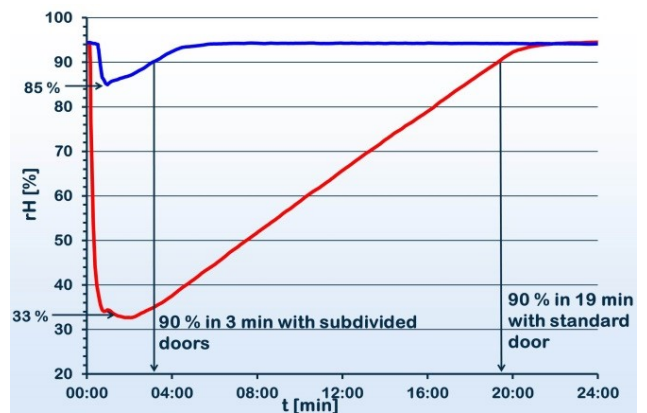

Recommended Accessories for active sterile humidity supply:



AEROpart® HUM

- sterile and pyrogen-free water
1000 ml

REF 16150



Magnetic hook

- diameter 48 mm

REF 15595



Intrafix® Air (B. Braun)

- I.V. administration set
tubing length 150 cm

REF 15417

SAFE Sens® pH monitoring



SAFE Sens® TrakStation™ with USB-Hub

Continuous pH monitoring of media during embryo culture within large format incubators

Advantages of the SAFE Sens® pH monitoring system:

- Independent, non-invasive monitoring of pH-value throughout the entire embryo cultivation
- Real time data of the pH-value every minute or every 30 minutes for up to 7 days
- Accurate measurements: ± 0.05 in a range of pH 7.00 to 7.60
- Monitoring of up to 8 chambers or incubators with one TrakStation™
- Installation in ≤ 10 minutes
- Intuitive and easy to use; easy to install by user



SAFE Sens® sv²-sensor in large format incubator



SAFE Sens® TrakPod™

Product features:

- SAFE Sens® measurement technology utilizes a patented and proven LED-based optical fluorescent system
- Included software for data recording capabilities and automatic alerts by e-mail
- Monitoring without staff intervention and door opening
- No petri-dish used (non-invasive)
- No costly, time consuming calibration required:
 - One qc² alignment tool needed per laboratory
 - Automatically adjusts fluorescent signal to restore to factory settings
 - No outside calibration services required, no incubator down time

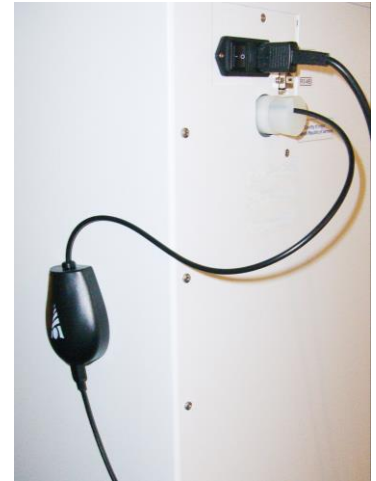

SAFE Sens® TrakPod™ installed in 200 l incubator Labo C201 via access port

SAFE Sens® TrakStation™

REF 16374

SAFE Sens® TrakPod™

REF 16457

SAFE Sens® sterile sv²-sensor
(10 pieces)

REF 16370

Sv²-sensors obtained from Labotect will only work with Labotect incubators

SAFE Sens® qc² alignment tool

REF 16371

Benchtop incubator Labo C-Top with integrated SAFE Sens® pH monitoring

REF 16377



SAFE Sens® qc² alignment tool on TrakPod™'s sv²-sensor in benchtop incubator Labo C-Top

Gasmonitor

Quality – Made in Germany

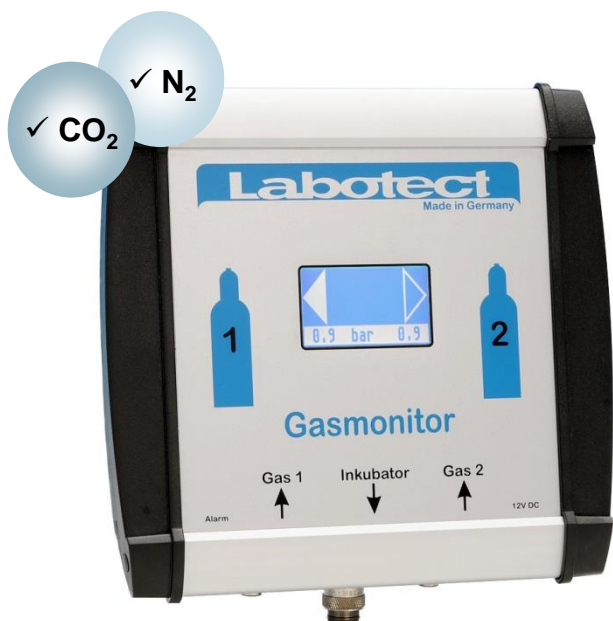

Automatic changeover unit

Features:

- Gas monitoring for CO₂, N₂ and mixed gas (max. 21% O₂)
- Monitors the gas supply and switches over automatically to second cylinder if supply is exhausted
- Ensures continuous gas supply without interruption
- Monitoring of gas pressures
- Optical and acoustical alarm if pressure is too low or too high
- Graphic display with touch screen

Technical data:

- Dimensions: 195 x 53 x 181 mm (w x d x h)
- Pressure range: 0.8 to max. 1.5 bar
- Alarm threshold and LOW switching point: P < 0.3 bar
- Alarm threshold HIGH: P ≥ 2.0 bar
- Maximum permitted connection pressure: P = 2 bar
- Remote alarm
- RS485 interface for data logging with optional available PC software LaboDat+
- Power supply: 12 V by Plug-in power supply 100 – 240 V AC, 60 W

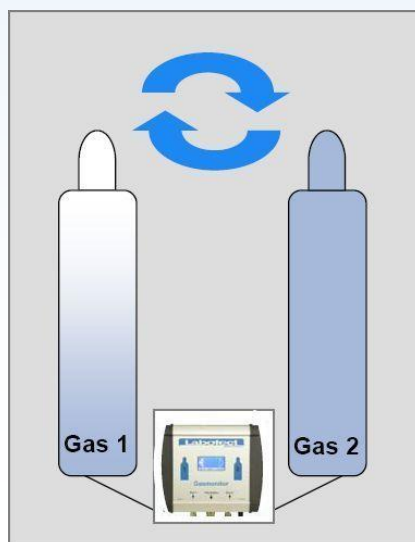

REF 14782

Scope of supply:

- Gasmonitor
- Quick couplers and further connectors
- Holder for installation at the wall
- Mains adapter
- Magnetic signs for labeling of gas cylinders

Optional accessory:



Support stand for Gasmonitor

REF 14943



Rev. 8_02/2020

LaboDat+

Quality – Made in Germany

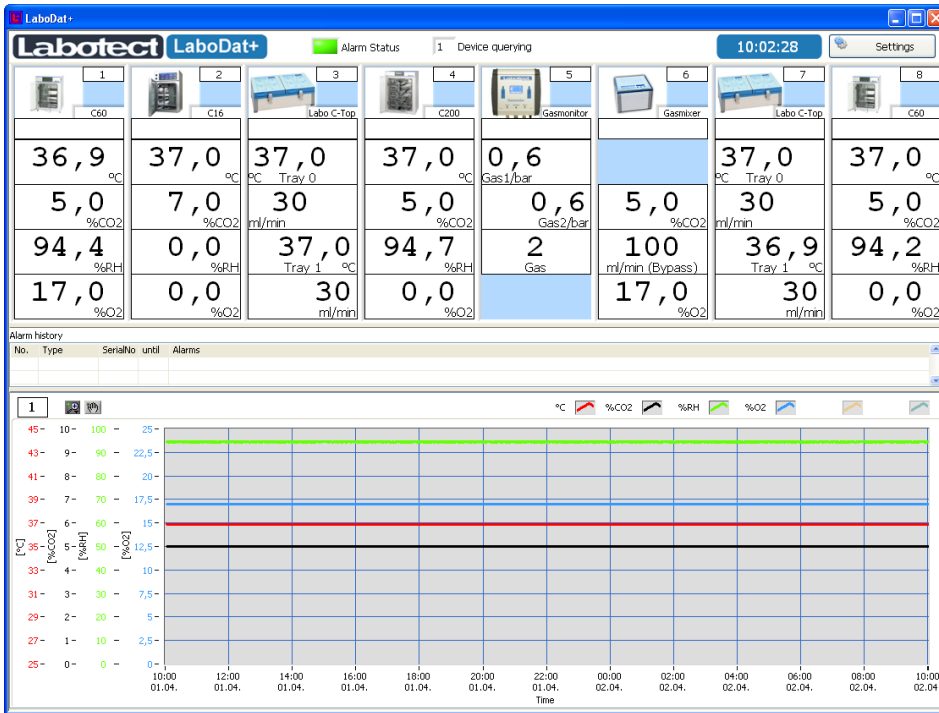

Software for documentation of incubation processes

Figure: Main window LaboDat+

Features:

- Display of actual and stored values
- Protected record of all measurements and alarms
- Visualization in diagrams or numerical values
- Compatible to Labotect devices with RS485 interface*
- Data export possible
- Language selection English / German
- Compatible up to Windows 10

Hardware:

- USB interface converter

REF 15125

Advantages:

- Documented record of incubation conditions
- Connection for up to 16 devices
- USB interface
- Report generation
- Data storage on server possible

Compatible devices:

- ➔ C16
- ➔ C60
- ➔ C200
- ➔ Labo C201
- ➔ Labo C-Top
- ➔ Labo Gas Mixer
- ➔ Gasmonitor

*depending on software version of the main board

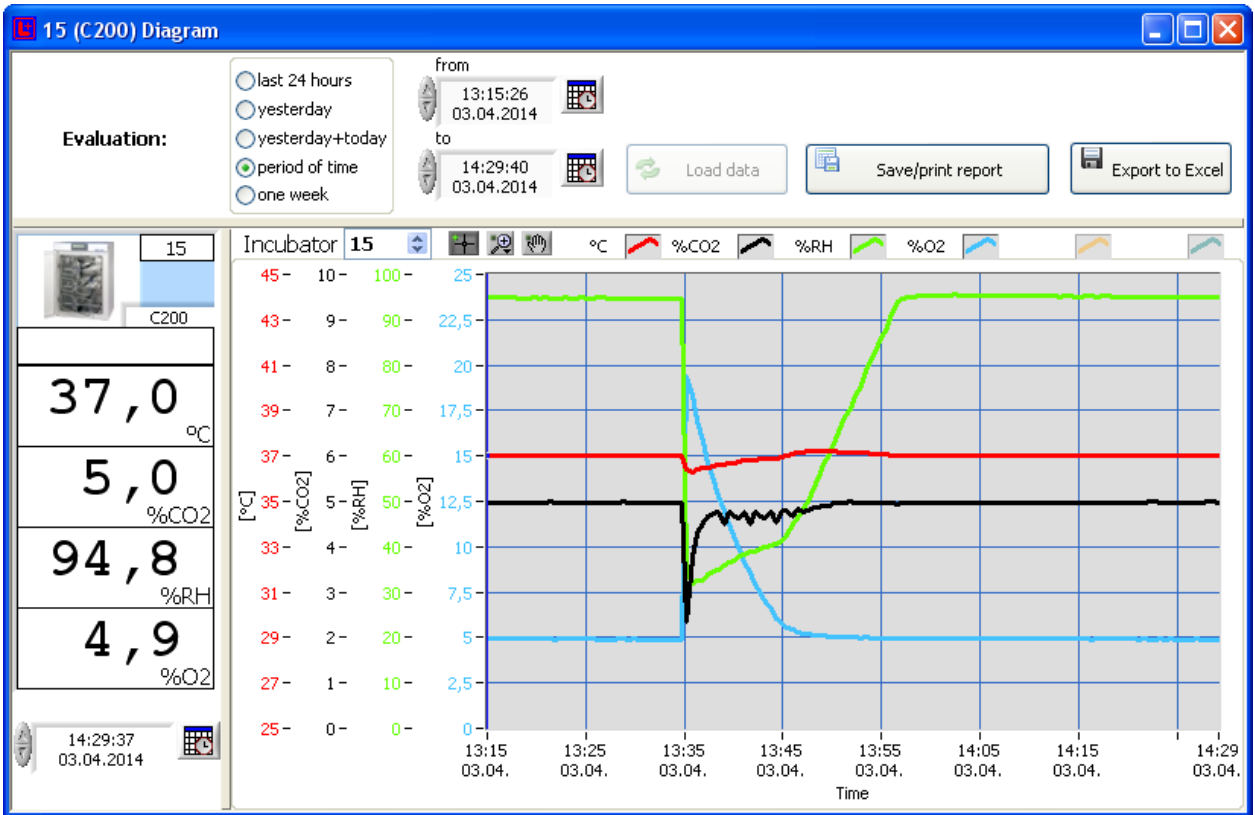

Figure: LaboDat+ evaluation of single device

Fermacidal D2®



- Without alcohol
- Fast acting
- MEA and HSSA tested

Product:

| | | |
|-----------------------------------|-----|-------|
| Spray bottle 50 ml | REF | 13045 |
| Spray bottle 250 ml | REF | 13048 |
| Bottle (screw cap) 500 ml | REF | 15213 |
| Spray bottle 1 l | REF | 13044 |
| Canister 5 l | REF | 13043 |
| Canister 10 l | REF | 15101 |
| Disinfectant wipes, 120 pieces | REF | 13046 |

Advantages:

- Ready-to-use disinfectant for surfaces and instruments
- Cleaning effect
- Long-term effective
- Smell-removal and neutralisation of odour-causing bacteria
- Also suitable for disinfection of CO₂ incubators

Microbiological efficacy:

- Bactericidal, e.g.: *Salmonella*, *Mycobacterium tuberculosis*
- Fungicidal, e.g.: *Trichophyton mentagrophytes*
- Selective virucidal, e.g.: *Hepatitis B*, *HIV*, *Rotavirus*, *Influenza A*, *Corona viruses*

(as specified by the manufacturer)

Features:

- Quaternary ammonium compounds
- Without alcohol and aldehyde
- Odourless
- Non-volatile
- Does not irritate the skin
- Does not stain
- Dissolves dried blood stains
- Good compatibility of materials like metal, rubber and plastic
- VAH listet and BauA registered

(as specified by the manufacturer)



Rev. 6_06/2020

Manoform®



Product:

| | |
|-------------------------------|-----------|
| Spray bottle 50 ml | REF 17665 |
| Spray bottle 250 ml | REF 14684 |
| Bottle 500 ml | REF 15648 |
| Bottle with dosing head 500ml | REF 17708 |
| Spray bottle 1 l | REF 17664 |
| Canister 5 l | REF 17709 |
| Canister 10 l | REF 17710 |

Advantages:

- Ready-to-use gentle disinfectant for hands and skin hygiene
- Free of alcohol and aldehydes
- Neutralisation of odour-producing bacteria
- Does not cause skin irritation, also suitable for sensitive skin

Microbiological efficiency:

- Bactericidal, e.g.: *E. Coli*
- Fungicidal, e.g.: *Candida*
- Effective against influenza and corona viruses, among others

(as specified by the manufacturer)

Features:

- Quaternary ammonium compounds
- Free of alcohol and aldehydes
- Odourless
- Non-volatile
- Does not irritate the skin
- Also suitable for sensitive skin with frequent use
- Leaves no stains
- BauA registered

(as specified by the manufacturer)



Rev. 0_05/2020

Icepur®



- **Disinfectant cleaner concentrate**
- **Free of alcohol**
- **Free of aldehydes**

Product:

Grip bottle 2 l

REF 15422

Canister 10 l

REF 15421

Advantages:

- For combined wipe disinfection and cleaning of surfaces and inventory
- For mask disinfection and cleaning in case of epidemics as well
- Free of any toxic or volatile components
- Protein and fat dissolving, neutralizes odour-producing bacteria

Microbiological efficiency:

- Bactericidal,
e.g.: *Salmonella*, *Mycobacterium tuberculosis*
- Fungicidal,
e.g.: *Trichophyton mentagrophytes*
- Selectively virucidal,
e.g.: Hepatitis B, HIV, Rotavirus

(as specified by the manufacturer)

Features:

- Quaternary ammonium compounds
- Without alcohol and aldehydes
- Odourless, neutralizes odour-producing bacteria
- Non-volatile
- Cleans and disinfects in one step
- Dissolves dried blood stains
- Leaves no stains
- Protein and fat dissolving
- Good compatibility with metals, rubber and plastics
- BauA registered

(as specified by the manufacturer)



Rev. 0_05/2020

Incubator-Filter-Box

Quality – Made in Germany



Separate unit for filtering the atmosphere in incubators

Features:

- Suitable for all cell culture incubators with minimum 60 l volume
- Eliminates particles, VOCs and other impurities in a very short time
- External controller outside the incubator
- No negative influence on the atmosphere inside the incubator
- Flexible use

Optional filters:

Gas filter A1 REF 14548

Composite filter A2-P3D REF 15415

Control unit Incubator-Filter-Box



Rev. 8_02/2020

Technical data:

- Composite filter is preinstalled = standard filter (to be replaced every 3 months)
- Operation under regular incubator atmosphere
- Dimensions: diameter 10 cm / height 12 cm
- Weight: approx. 600 g (when using composite filter)
- Switches on automatically for 5 - 6 minutes; starts again after a break of 40 minutes

REF 14526

Gas In-Line-Filter

Quality – Made in Germany

Provides effective protection for your embryos and cells
Removes VOCs and particles from gas before it enters your incubator

Advantages:

- Can be used with any CO₂ incubator
- For CO₂, N₂, and premixed gas (≤ 21 % O₂)
- Connection for quick coupling - fast and safe installation
- Removes volatile organic compounds (VOCs) from gas
- Additional PE-layer removes particulates



Characteristics:

- Activated carbon filter formed by sintering
- Removes VOCs (e.g. oil vapours, aldehydes, furans, odorous substances, aromatic compounds, ketones, pyridines, and CHC) from gases entering the incubator
- Excellent adsorption capacity and very low pressure loss
- For pressures up to 2 bar (Labotect CO₂ incubators: 0.8 bar)
- For tubing 6/4x1 (other diameters upon request)
- For best results, we recommend to change the filter every 3 months (the maximum recommended useful life is up to 6 months)



REF 16586 Gas In-Line-Filter with integrated connection for quick coupling

REF 16587 Coupling body for tubing 6/4x1 (other diameters upon request)

CE Rev. 4_02/2018

InControl 1050

Quality – Made in Germany



Independent measuring device for control and evaluation of CO₂, temperature and O₂

Features:

- Accurate measuring of CO₂, temperature and optional O₂
- Single or continuous measurement in arbitrary intervals
- Measurement and documentation of multiple incubators
- Documentation of measurements with date, time and incubator number
- Easy menu navigation
- Continuous operation by Li-Ion battery or mains adapter possible
- Data-Download via USB; PC software DataVISUAL`19 incl.
- Compatible with Windows up to and including Windows 10

Scope of supply:

- InControl 1050 including Transport case
- Mains adapter
- Tubing, adapter and condensation trap
- PC software: DataVISUAL`19 (on USB-Stick)
- USB data cable

REF 14709



Technical data

Case:

- Plastic (ABS)

CO₂ measurement:

- Dual beam IR sensor
- Range: 0 – 10 % CO₂
- Display definition: 0.1 % CO₂
- Accuracy:
 - 0 – 6 % CO₂ ± 0.2 % CO₂
 - 6 – 10 % CO₂ ± 0.3 % CO₂
- Sample volume per measurement (2 min.): approx. 0.8 l

Temperatur measurement:

- Platinum temperature sensor PT1000
- Range: 0 – 100 °C
- Display definition: 0.1 °C
- Accuracy:
 - 20 – 50 °C ± 0.2 °C
 - 50 – 100 °C ± 0.3 °C

O₂ measurement:

- Galvanic sensor
- Range: 0 – 100 % O₂
- Display definition: 0.1 % O₂
- O₂ sensor not included

Data logger:

- Recording of measurement logging in arbitrary intervals
- Output of measurements via:
 - backlit LCD
 - PC software Data Visual'19 (via USB data cable)
- Interval for data logging: 15 – 120 min. adjustable in steps of 5 minutes
- storage of max. 1008 measurements with date and time

Power supply:

- Rechargeable Li-Ion battery
- Power supply 100 – 240 V AC, 5 V DC 1.5 A

Operation time:

- Use of rechargeable battery approx. 4 h
- Time to recharge battery approx. 4 h



Optional accessories:



Sensor for O₂ measurement

REF 10556



Flat tape sensor PT1000 for temperature measurement inside Labo C-Top or other benchtop incubators

REF 15064



Surface sensor for temperature measurement

REF 10537



Tubing Set for CO₂ measurements for ESCO Miri®

REF 16440



Rev. 8_05/2020

Hot Plate 062

Quality – Made in Germany



Hot Plate for laboratory and scientific use

Features:

- Temperature control between 27 °C and 45 °C
- Homogeneous temperature distribution
- Planar surface for optimal heat transfer to heating blocks, culture dishes and slides
- Short heating up time
- Very compact and extremely flat
- Space saving due to separate control unit

Technical data:

- Dimensions: 274 x 214 x 18 mm (w x d x h)
- Weight: 2.4 kg
- Accuracy: ± 0.2 °C
- Temperature distribution: ± 0.3 °C
- Heating up time: < 10 min.
- Power supply: 100 – 240 V AC, 50/60 Hz, 60 W
- Temperature adjustable between 27 °C and 45 °C
- Safety class II

Scope of supply:

- Hot plate
- Controller with mains adapter REF 13854

Additional equipment:

- Retractor frame REF 15943



Rev. 5_02/2020

Hot Plate 100

Quality – Made in Germany



Hot Plate for laboratory and scientific use

Versatile use between 27 °C and 100 °C: Heating, drying, stretching

Features:

- Temperature control between 27 °C and 100 °C
- Homogeneous temperature distribution
- Planar surface for optimal heat transfer to heating blocks, culture dishes and slides
- Short heating up time
- Compact, flat, with carry handles
- Space saving due to separate control unit

Technical data:

- Dimensions: 314 x 214 x 23 mm (w x d x h)
- Weight: 2.9 kg
- Heating up time (approx.):
37 °C: 2 min., 100 °C: 9 min.
- Power supply:
100 – 240 V AC, 50/60 Hz, 140 W
- Temperature adjustable between 27 °C and 100 °C
- Safety class I

Scope of supply:

- Hot plate
- Controller with mains adapter

REF 15049



Rev. 4_02/2020

Hot Plate A3

Quality – Made in Germany



Big hot plate for laboratory and scientific use

Features:

- Temperature control between 27 °C and 45 °C
- Homogeneous temperature distribution
- Planar surface for optimal heat transfer to heating blocks, culture dishes and slides
- Easy to clean glass surface
- Short heating up time
- Extremely flat with big work surface
- Space saving due to separate control unit

Technical data:

- Dimensions: 420 x 300 x 23 mm (w x d x h)
- Weight: 5.5 kg
- Heating up time: < 15 min.
- Power supply:
100 – 240 V AC, 50/60 Hz, 140 W
- Temperature adjustable between 27 °C and 45 °C
- Protection class IPX1 (Hot Plate)
- Protection class IPX0 (Controller)
- Cable length between Controller and Hot Plate 1.5 m
- Safety class I

Scope of supply:

- Hot plate
- Controller with mains cable REF 15668

Additional equipment:

- Retractor frame REF 15942



Rev. 4_02/2020

Hot Plate A4

Quality – Made in Germany



Hot Plate for laboratory and scientific use

Features:

- Robust and planar glass surface
- Homogeneous temperature distribution
- OLED display for intuitive and easy-to-use user menu
- Functional buttons with haptic feedback via vibration (disengageable)
- Extremely flat and space saving
- Cleaning and disinfection with all common detergents

Technical data:

- Dimensions: 300 x 210 x 15 mm (w x d x h)
- Usable surface area: 255 x 140 mm
- Temperature stability: ± 0.2 °C
- Temperature homogeneity: ± 0.3 °C
- Weight: 1050 g (w/o mains adapter)
- Heating up time: approx. 10 min
- Adjustable temperature range: 27-45 °C (2 °C above ambient temperature)
- Power supply: 100 – 240 V AC, 60 W
- Cable length: Hot Plate to mains adapter 1.8 m, mains adapter to plug 1.8 m

(Specifications subject to change without notice.)

Scope of supply:

REF 16481 Hot Plate A4 with mains adapter and cable

CE Rev. 2_02/2018

Blockthermostat

Quality – Made in Germany



Designed to maintain the temperature of biological materials

Features:

- Temperature adjustable between 27 °C and 45 °C
- Homogeneous temperature distribution
- Heating up time only approx. 40 min.
- Use of different heating blocks

Technical data:

- Dimensions thermostat:
290 mm x 175 mm x 110 mm
(W x D x H)
- Power supply:
100 – 240 V AC, 50/60 Hz, 60 W
- Temperature control between
27 °C and 45 °C
- Accuracy: ± 0.2 °C
- Temperature distribution: ± 0.2 °C
- Heating up time from 22 °C to 37 °C:
approx. 40 min.
- Safety class II

REF 10719 (without heating block)

REF 13855 (with heating block: REF 10264)

REF 13896 (with heating block: REF 10277)



Rev. 5_02/2020

CellTrans⁺

Qualität – Made in Germany



CO₂ transport incubator for a secure and mobile preservation of biological material

Technical data:

Power supply:

- 100 V - 240 V, 60 W
- 12 V car cable
- Duration with completely charged accumulator:
 - At 2 °C ambient temperature approx. 4 h
 - At 10 °C ambient temperature approx. 6 h
 - At 23 °C ambient temperature approx. 10 h
- Charge time approx. 7 h

Dimensions:

- Exterior: 386 x 251 x 370 (l x w x h in mm)
- Interior: ø 160 mm, height 130 mm, volume approx. 2.6 l
- Empty weight approx. 8.5 kgs

Temperature control:

- Control range 30 °C – 42 °C at 3 °C above room temperature
- Temperature homogeneity ± 0.2 °C
- Temperature stability ± 0.1 °C

CO₂ regulation:

- Control range 0 – 10 % CO₂
- Control accuracy 0.3 % CO₂

CO₂ pressure tank:

- Capacity 0.4 l
- Pressure 8 bar

Classification:

- Safety class I
- Conform to EN 61010

Advantages:

- Can also be used as back up in case of incubator or power outage
- Temperature adjustable between 30 °C and 42 °C
- CO₂ adjustable between 0 % and 10 %
- Reliable humidity system
- Easy handling and cleaning
- Compact Design
- Insert for 16 Falcon tubes of 5 ml and 13 ml each

REF 16529

(Specifications subject to change without notice.)

Product features:

Interior chamber:

- Anodized aluminium
- Insert: Stainless steel

Temperature:

- Over-all heating of lateral surface, bottom and lid of incubation chamber
- Homogeneous temperature distribution

Humidity:

- Via humidifying disc \varnothing 50 mm

CO₂:

- Dual beam infrared sensor
- Measurements independent of temperature and humidity

Recovery times:

- Short recovery times for all adjustable parameters through microprocessor controlled regulation

Easy navigation:

- Menue guided
- Backlid LCD

Interfaces:

- USB interface for data evaluation via PC Software DataVISUAL '19 (in scope of supply)
(compatible up to Windows 10)

Diagnostic system:

- Visual and acoustic signal for alarms
- Monitoring of temperature, CO₂, pressure, humidity, battery and lid of interior chamber

Scope of supply:

- Transport incubator CellTrans⁺
- Mains adapter
- Car voltage adapter cable
- Connection hose for CO₂ supply
- Disc for humidification
- USB data cable
- PC software DataVISUAL '19 (on USB stick) for data evaluation
- Insert for 16 Falcon tubes of 5 ml and 13 ml each

Recovery times CO₂ after lid opening:

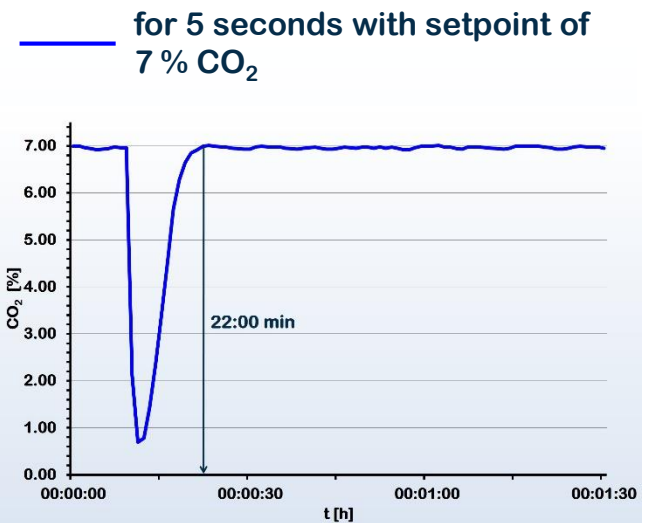

Optional equipment:

- Pressure reducing valve for CO₂ 0 – 10 bar

REF 17441

- Inserts for CellTrans⁺



Insert for up to three shelves for various plates / dishes

REF 17662

- Shelves for inserts for CellTrans⁺



Shelf for one microtiter plate for insert REF 17662

REF 17540



Shelf for two 4-well dishes for insert REF 17662

REF 17554



Shelf for four round dishes (base diameter ~ 5 mm) for insert REF 17662

REF 17555

CellTrans 2018

Quality – Made in Germany



Transport incubator for a secure and mobile preservation of specimen, culture media etc.

Technical data:

Power supply:

- 115 V or 230 V AC, 50/60 Hz
- 12 V DC with car voltage via adapter cable

Dimensions:

- Outside: 385 x 245 x 305 (l x w x h in mm)
- Inside: approx. 312 x 167 x 140 mm (l x w x h in mm)
- Weight: approx. 4.7 kg

Temperature:

- Available between 32 °C and 39 °C (to be advised before order)
- Accuracy of regulation ± 0.3 °C (measured with heating block REF 10264)

Heating up time:

- approx. 2 h

CO₂ concentration:

- 5 % (different concentrations possible)
- Heating block inside necessary
- Connection to CO₂ supply with pre-pressure of 0.8 bar necessary
- CO₂ accuracy ± 0.3 % CO₂ (when supplied with CO₂ with pre-pressure of 0.8 bar ± 0.05 bar)

(Specifications subject to change without notice.)

Features:

- Secure transport of cells without electric mains and CO₂ connection
- Factory-aligned parameters: 37 °C and 5 % CO₂
- Different temperature or CO₂ concentration possible (to be advised before order)
- Operation at 12 V car voltage possible
- Use of different heating blocks
- Easy handling and cleaning
- Compact Design

Parameters* during transport without connection to electric mains:

| Transport time | 0 min | 10 min | 30 min | 60 min |
|-------------------------------|---------|---------|---------|---------|
| Temperature | 37.0 °C | 36.6 °C | 35.5 °C | 34.0 °C |
| CO ₂ concentration | 5.0 % | 4.9 % | 4.8 % | 4.7 % |

*The measurements relate to an ambient temperature of 23 °C .

REF 16666 (without heating block)



Rev. 3_03/2021

Thermo Cell Transporter 3018

Quality – Made in Germany



Transport incubator for safe and versatile use

Features:

- Factory-aligned temperature at 37 °C
- Different temperature possible (to be advised before order)
- Continuous operation with power supply, car voltage or integrated accumulator during transport
- Operation with batteries up to 5 h*
- Compact design

* at 22 °C ambient temperature

Technical data:

- Dimensions: 111 x 111 x 215 (w x d x h in mm)
- Weight: 2.4 kg
- Power supply: 100 – 240 V AC, 50/60 Hz, 60 W
12 V DC, 1.5 A car connection cable
- Temperature: between 32 °C and 42 °C available (to be advised before order)
- Accuracy of regulation: ± 0.3 °C
- Operation time:
 - with power supply or 12 V car voltage continuously
 - with accumulator approx. 5 h*
- Heating up time 22 °C to 37 °C: approx. 1 h*
- Charging time of accumulator: approx. 3 h
- For use with 8 x 13 ml Falcon tubes (REF 13881) or 2 x 13 ml and 8 x 5 ml Falcon tubes (REF 16518)
- Safety class II

Scope of supply:

- Basic unit
- Power supply unit
- Car connection cable

REF 13881 for 8 x 13 ml Falcon tubes

REF 16518 for 2 x 13 ml and 8 x 5 ml Falcon tubes



Rev. 5_02/2020

Aluminium-Wärmeblöcke

Qualität – Made in Germany

Als Zusatz für CellTrans 2018, Cell-Trans 4016, Blockthermostat, Aspirator 3 mit Wärmeplatte und Wärmeplatten sind folgende Produkte erhältlich:

Große Aluminium-Wärmeblöcke zur Aufnahme von



22 Falconröhrchen à 5 ml
 $x = 54 \text{ mm}$, $\varnothing = 12,2 - 12,4 \text{ mm}$
 oder 38 Falconröhrchen à 13 ml
 $x = 66 \text{ mm}$, $\varnothing = 16,8 - 17,0 \text{ mm}$
 (Mischbestückung möglich)

REF 10264



26 Röhrchen à 25 ml oder 26 ml
 (z.B. Falcon, Sarstedt o.ä.)
 $x = 68 \text{ mm}$, $\varnothing = 23,9 - 24,1 \text{ mm}$

REF 10277

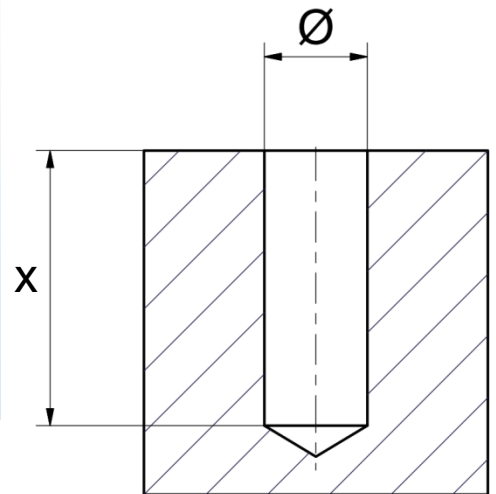

Kleine Aluminium-Wärmeblöcke* zur Aufnahme von



8 Falconröhrchen à 13 ml
 $x = 60,5 \text{ mm}$, $\varnothing = 16,8 - 17,0 \text{ mm}$

REF 12974



5 Röhrchen à 25 ml oder 26 ml
 (z.B. Falcon, Sarstedt o.ä.)
 $x = 70 \text{ mm}$, $\varnothing = 24,0 - 24,1 \text{ mm}$

REF 12977

*Die kleinen Wärmeblöcke sind für den CellTrans 2018 nicht passend

Große Aluminium-Wärmeblöcke zur Aufnahme von



12 CCD-Röhrchen
 $y = 72 \text{ mm}$, $\varnothing = 35,5 - 35,6 \text{ mm}$

REF 14413



12 Falconröhrchen à 50 ml
 $y = 81 \text{ mm}$, $\varnothing = 29,95 - 30,05 \text{ mm}$

REF 14870

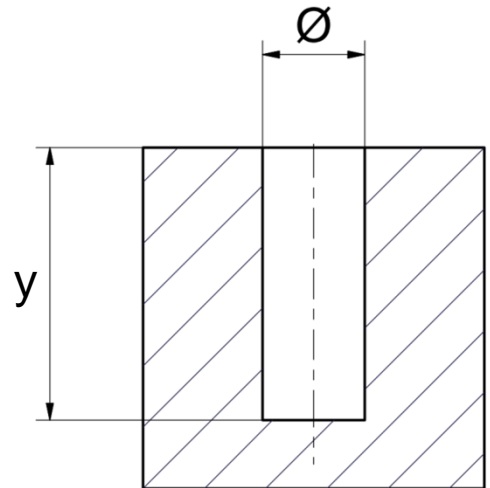

Rev. 9_02/2021

Embryo Transfer Catheter

Quality – Made in Germany



Special & proven design

- The Luer connection at the proximal end of the guiding cannula permits trouble-free insertion of the inner catheter
- The penetration depth and the direction can be set at the guiding cannula using a slide ring
- Atraumatic owing to the curved guiding cannula with a ball end, allowing the catheter to be used reliably even with difficult anatomic conditions
- Metal reinforced inner catheter shaft allows simple, safe handling
- Three different lengths permit optimal adaption to different anatomies
- Disposable product, double sterile packed

Regulatory Standards

- Manufacturer certified as per ISO 13485
- Class Is according to Directive 93/42 EEC
- To be used by trained personnel only

Enhanced Safety and Reliability

- Each batch MEA (Mouse Embryo Assay) and LAL (Endotoxin Assay) tested
- Biocompatibility conforming to ISO 10993
- Validated gamma-sterilisation
- Production under controlled conditions

Specifications

Packaging: normal

Embryo transfer catheter, length: 150 mm

REF 13365

Embryo transfer catheter, length: 190 mm

REF 13366

Embryo transfer catheter, length: 230 mm

REF 13369



Packaging: hard blister, inner catheter and guiding cannula single packed

Embryo transfer catheter single packed, length: 190 mm

REF 14690



Insemination catheter

Quality – Made in Germany



Features:

- Flexible, round tip with lateral openings for atraumatic insertion of the catheter
- Highest safety – each batch Mouse Embryo Assay (MEA) and Endotoxin Assay (LAL) tested
- Biocompatibility conforming to ISO 10993
- Validated electron beam sterilization
- Class Is according to Directive 93/42/EEC
- To be used by trained personnel only

REF 13372

CE0123

Rev. 6_02/2020

Holding Pipettes

Quality – Made in Germany

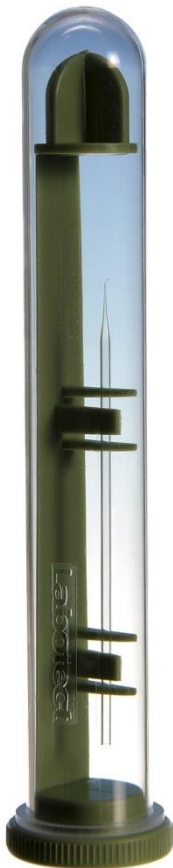

Holding pipette for in-vitro fertilization and manipulation of the ovum

Features:

- Each batch is MEA (Mouse Embryo Assay) and LAL (Endotoxin Assay) tested
- Ideal in handling and safe for transportation
- With expedient size and angle
 - Lumen diameter set for stable immobilisation of cells
 - Optimal degree values
- Packaging
 - Individually sterile packed
 - Easy handling during pipette removal
 - Special brackets protect pipette from damage during transportation
 - Colour coding simplifies identification
- Validated electron beam sterilization
- Class Is according to Directive 93/42/EEC

Designed for precision work

Available in the following angles:

Holding pipette, angle 35° REF 14697

Holding pipette, angle 30° REF 14698

Technical data

Specification:

- Inner diameter $20\ \mu\text{m} \pm 5\ \mu\text{m}$
- Outer diameter $100\ \mu\text{m} \pm 10\ \mu\text{m}$

Holder:

- Color code GREEN
- Material POM

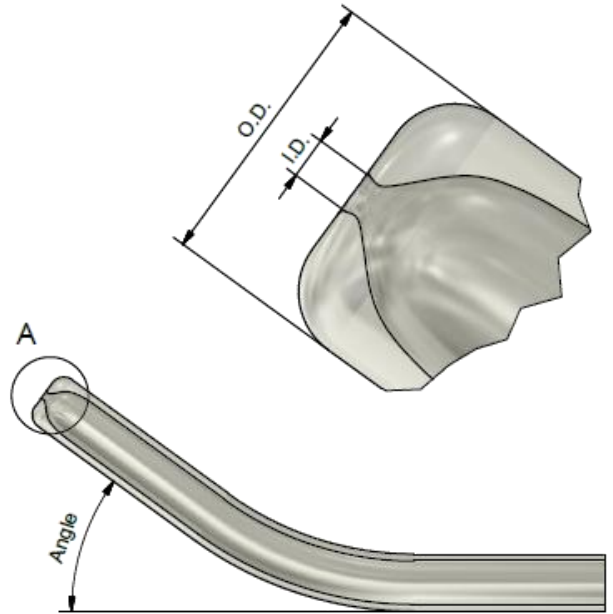

Microinjection Pipettes

Quality – Made in Germany



Microinjection pipettes for in-vitro fertilization and manipulation of the ovum

Features:

- Each batch is MEA (Mouse Embryo Assay) and LAL (Endotoxin Assay) tested
- Ideal in handling and safe for transportation
- With expedient size and angle
 - Tip with spike
 - Optimal degree values
- Packaging
 - Individually sterile packed
 - Easy handling during pipette removal
 - Special brackets protect pipette from damage during transportation
 - Colour coding simplifies identification
- Validated electron beam sterilization
- Class Is according to Directive 93/42/EEC

Designed for precision work

Available in the following angles:

Microinjection pipette,
angle 35°

REF 14699

Microinjection pipette,
angle 30°

REF 14700

Technical data

Specification:

- Inner diameter 4.0 – 5.0 μm
- Outer diameter 5.5 – 6.5 μm

Holder:

- Color code RED
- Material POM

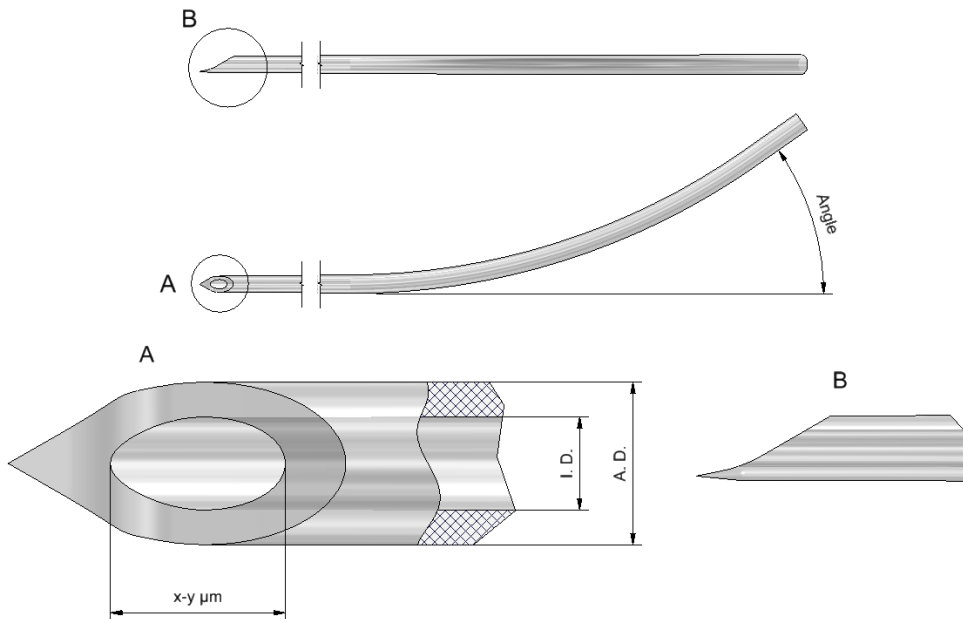

ACTIVE VIBRATION ISOLATION IVF WORKSTATION



Mobile cabinet optional

ACTIVE VIBRATION ISOLATION IVF WORKSTATION



Accurion's IVF Workstation has been specially designed for the use with in-vitro-fertilization so that biologists can ergonomically sit in front of their microscope.

The workstation consists of a lab table with integrated active vibration isolation system to actively compensate incoming vibrations. The incorporated i4 system is self explanatory with a control panel of only three buttons which allows the user to completely focus on the application. An active system enables you to work without disruptions and will increase your efficiency.

Due to the nonisolated surface space the user's arms can rest comfortably without impacting the procedure. In contrast to heavy granite tables its sleek design allows using your space to full capacity and also complements your existing furniture. In addition to that the active isolation system provides superior isolation performance and overcomes the disadvantages usually associated with passive systems.

Aside from functionality and stability, Accurion paid particular attention to medical standards, e.g. proper surface coating. A mobile cabinet would be available as optional accessory.



■ IVF Workstation with Nikon Eclipse Ts2R-FL
Mobile cabinet optional

IVF WORKSTATION

Isolated surface i4 (W × D): 400 × 500 mm | 15.7" × 19.7"

Overall dimensions (W × D × H): 1300 × 800 × 784 mm | 51.2" × 31.5" × 30.9"

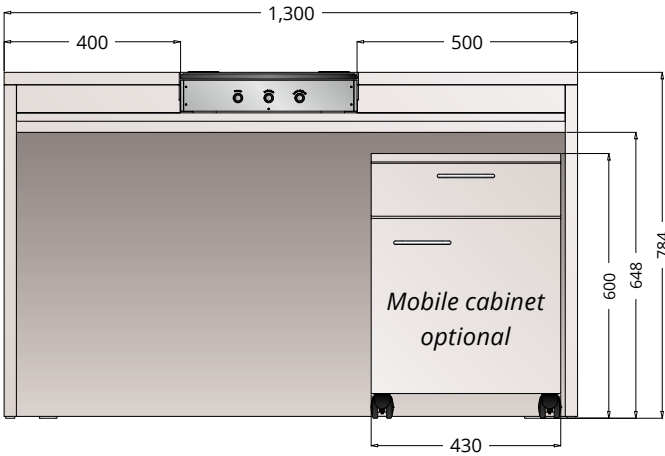

Top View

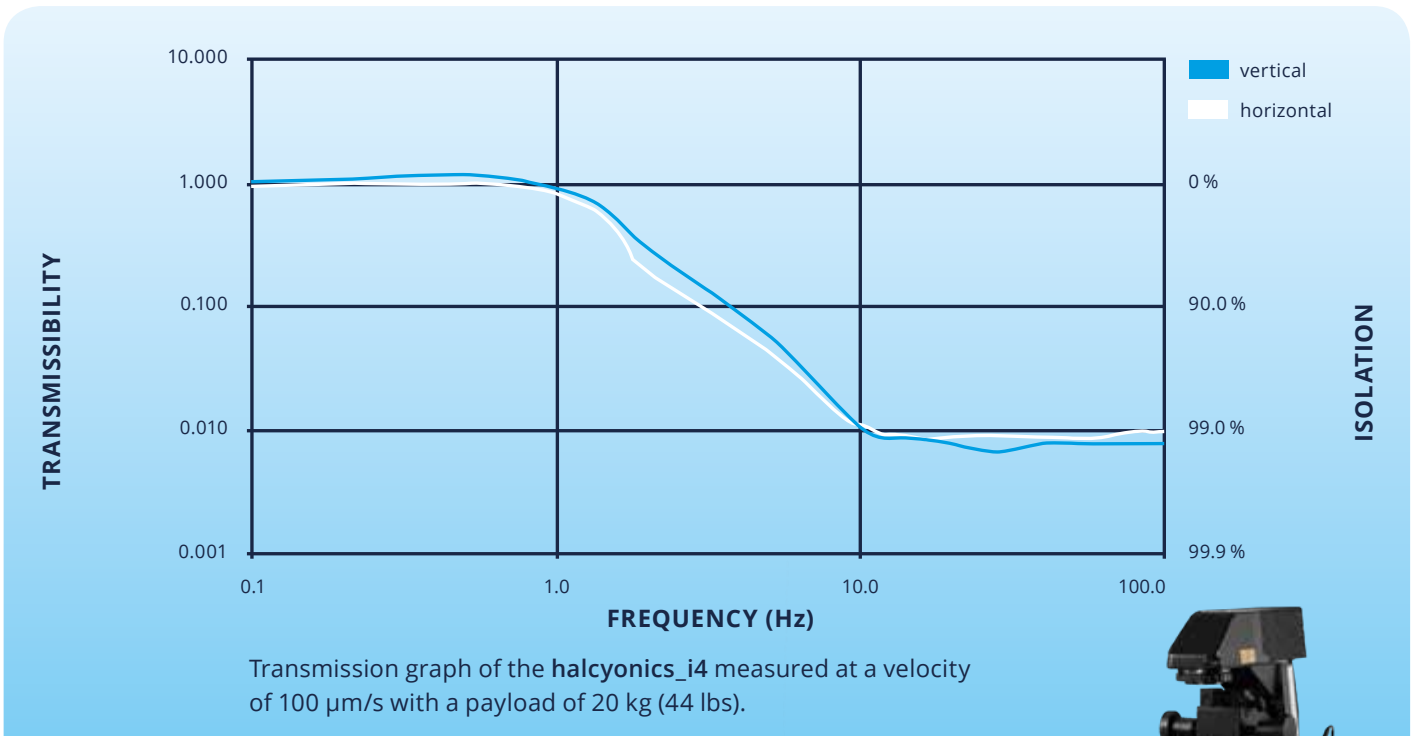
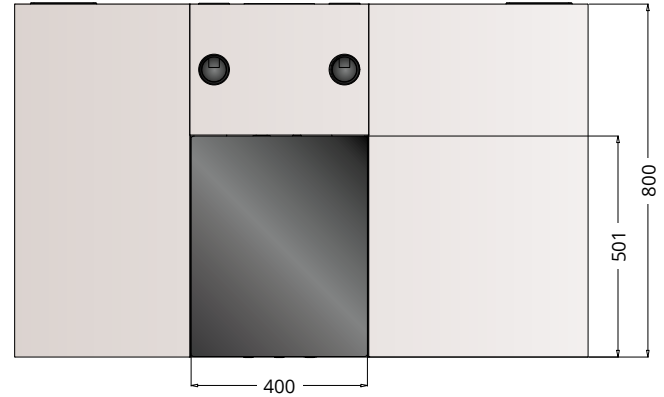

KEY FEATURES:

- Isolation in all six degrees of freedom.
- Automatic load adjustment and transportation lock.
- Vibration cancellation even in the low frequency range due to the lack of a natural low frequency resonance.
- AC power from an electrical outlet is sufficient; no compressed air supply is needed.
- Excellent position stability.
- Response time only 0.5 ms.

■ IVF Workstation with Nikon Eclipse T12



| SPECIFICATIONS | IVF Workstation |
|--|---|
| Dimensions of isolated surface (L × W) | 400 × 500 mm 15.7 × 19.7 inch |
| Load capacity on isolated surface | 0 – 120 kg 0 – 265 lbs |
| Force directions | Active compensation in all six degrees of freedom. |
| Isolation performance | > 5 Hz = 25 dB (94.4 %) > 10 Hz = 40 dB (99 %) |
| Active bandwidth | 0.6 – 200 Hz* (passive isolation beyond 200 Hz) |
| Response time | 0.5 ms** |
| Max. correction forces | Vertical ± 8 N Horizontal ± 4 N |
| Table top material on isolated surface | Powder coated aluminum |
| Table top material non-isolated surface | Medium density fiberboard with outer melamin resin surface |
| Top plate surface flatness | ± 0.10 mm over complete surface |
| Environmental and operational requirements | Electrical voltage: 100 – 240 V / 47 – 63 Hz Power consumption: Typically 40 – 45 W Operating temperature: 15 – 40 °C / 59 – 104 °F Relative humidity: 0 – 60 % Operating altitude: < 2,500 m / 8,100 ft |
| Electrical safety | CE certified according to directive 2014/35/EG |
| EMC | CE certified according to directive 2014/30/EG |

*The low-pass characteristics of the spring-mass combination dominate the dynamic behavior of the isolation system above 200 Hz. The part of the active isolation decreases with increasing frequency.

**The response time determines when the system starts to actively isolate an incoming vibration after detection by the sensors.

Errors and omissions excepted.

Part numbers:
REF 16877 – IVF Workstation (without mobile cabinet)
REF 16880 – Active vibration isolation system (400 × 500 × 90 mm³)

Labotect Labor-Technik-Göttingen GmbH
Kampweg 12
37124 Rosdorf
Germany

Tel.: +49 551 505 01-0
Fax: +49 551 505 01-11
E-Mail: info@labotect.com
Web: www.labotect.com

Labotect

Labor-Technik-Göttingen

www.labotect.com
sales@labotect.com
+49 551 / 50 50 125



Address:
Labotect Labor-Technik-Göttingen GmbH
Kampweg 12
37124 Rosdorf
Germany

Postal address:
Labotect Labor-Technik-Göttingen GmbH
Postfach 200212
37087 Göttingen
Germany

Phone +49 551 50 50 10
Fax +49 551 50 50 111
Email: info@labotect.com
Web: www.labotect.com

Court of register: Göttingen: HRB 1394
WEEE-Reg-No: DE 86039820
Managing director:
Della Schinkel-Fleitmann
Dr. Friederike Fleitmann